

Eaton® 9315/9390/9395

**Fixed Master Sync Control
Installation and Operation Manual**



Powering Business Worldwide

IMPORTANT SAFETY INSTRUCTIONS SAVE THESE INSTRUCTIONS

This manual contains important instructions that you should follow during installation and maintenance of the UPS and batteries. Please read all instructions before operating the equipment and save this manual for future reference.

CONSIGNES DE SÉCURITÉ IMPORTANTES CONSERVER CES INSTRUCTIONS

Ce manuel comporte des instructions importantes que vous êtes invité à suivre lors de toute procédure d'installation et de maintenance des batteries et de l'onduleur. Veuillez consulter entièrement ces instructions avant de faire fonctionner l'équipement et conserver ce manuel afin de pouvoir vous y reporter ultérieurement.

Eaton and X-Slot are registered trademarks of Eaton Corporation or its subsidiaries and affiliates. National Electric Code and NEC are a registered trademarks of National Fire Protection Association, Inc. All other trademarks are property of their respective companies.

©Copyright 2005–2011 Eaton Corporation, Raleigh, NC, USA. All rights reserved. No part of this document may be reproduced in any way without the express written approval of Eaton Corporation.

Table of Contents

1	Introduction	1-1
1.1	Conventions Used in This Manual	1-3
1.2	Safety Warnings	1-3
1.3	For More Information	1-4
1.4	Getting Help	1-4
2	Installation Plan and Unpacking	2-1
2.1	Creating an Installation Plan	2-1
2.2	Preparing the Site	2-1
2.2.1	Environmental and Installation Considerations	2-1
2.2.2	Eaton Fixed Master Sync Control and Master Interface Wiring Preparation	2-6
2.3	Inspecting and Unpacking the Eaton Fixed Master Sync Control or Master Interface	2-6
3	Installation	3-1
3.1	Installation	3-2
3.2	Installation and Wiring with an Eaton 9315 UPS	3-5
3.3	Installation and Wiring with an Eaton 9390 UPS	3-15
3.4	Installation and Wiring with an Power Xpert 9395 UPS	3-19
4	Operation	4-1
4.1	Startup for UPS Systems Equipped with an Eaton Fixed Master Sync Control	4-1
4.2	Understanding Eaton Fixed Master Sync Control Operation	4-1
4.3	Operation	4-3
4.4	Maintenance Operations	4-4
5	Warranty	5-1

List of Figures

Figure 1-1. Eaton Fixed Master Sync Control	1-1
Figure 1-2. Eaton Fixed Master Sync Control with Door Open	1-2
Figure 1-3. Eaton Sync Control Master Interface Panel	1-2
Figure 2-1. Eaton Fixed Master Sync Control Dimensions – Front View	2-2
Figure 2-2. Eaton Fixed Master Sync Control Dimensions – Side Views	2-3
Figure 2-3. Eaton Master Interface Enclosure Dimensions - Front View	2-4
Figure 2-4. Eaton Master Interface Enclosure Dimensions - Side, Rear, and Bottom Views	2-5
Figure 3-1. Fixed Master Sync Control with Master Interface Enclosure Functional Diagram	3-1
Figure 3-2. Typical Eaton Fixed Master Sync Control Control Wiring Termination Locations	3-2
Figure 3-3. Eaton Fixed Master Sync Control TB1 Terminal Block Detail	3-3
Figure 3-4. Typical Control Wiring Termination Locations for Eaton Master Interface Enclosure	3-4
Figure 3-5. TB6 Terminal Block Detail (All Systems)	3-10
Figure 3-6. Fixed Master Sync Control Interface Location for 30-80 kVA Single Module 9315 UPS System	3-10
Figure 3-7. Fixed Master Sync Control Interface Location for 100-160 kVA Single Module 9315 UPS System	3-11
Figure 3-8. Fixed Master Sync Control Interface Locations for 200-300 kVA Single Module 9315 UPS System	3-12
Figure 3-9. Fixed Master Sync Control Interface Location for 400-500 kVA Single Module 9315 UPS System	3-13
Figure 3-10. Fixed Master Sync Control Interface Location for 750 kVA Single Module 9315 UPS System	3-14
Figure 3-11. Eaton 9390 UPS (40–80 kVA) Interface Locations for Eaton Fixed Master Sync Control	3-17
Figure 3-12. Eaton 9390 UPS (100–160 kVA) Interface Locations for Eaton Fixed Master Sync Control	3-18
Figure 3-13. TB6 Terminal Block Detail	3-18
Figure 3-14. TB6 Terminal Block Detail (All Systems)	3-21
Figure 3-15. Power Xpert 9395 UPS (225–275 kVA) Interface Locations for Eaton Fixed Master Sync Control	3-21
Figure 3-16. Power Xpert 9395 UPS and Plus 1 UPS (450–550 kVA) Interface Locations for Eaton Fixed Master Sync Control	3-22
Figure 3-17. Power Xpert 9395 UPS and Plus 1 UPS (650–825 kVA) Interface Locations for Eaton Fixed Master Sync Control	3-23
Figure 3-18. Power Xpert 9395 UPS (1000–1100 kVA) Interface Locations for Eaton Fixed Master Sync Control	3-24
Figure 3-19. Relay Interface Card	3-25
Figure 3-20. Relay Interface Card Terminals	3-25
Figure 4-1. Synchronization Reference Control	4-2
Figure 4-2. Eaton Fixed Master Sync Control Controls and Indicators	4-3

Chapter 1

Introduction

The Eaton® Sync Control maintains the critical load outputs of two separate single UPS systems in synchronization. Use of the Eaton Fixed Master Sync Control provides the uninterrupted transfer of the load from one load bus to another by means of downstream, dual-source, solid-state, transfer switches. Without the load sync option, the two system output (critical load) buses could become out of phase with each other. This condition occurs when suitable bypass sources are not available or when the bypass sources feeding each system are not in sync with each other. Examples of this condition are two systems supplied by separate generator sets, or the bypass sources for the two systems are lost.

The additional use of the optional Sync Control Master Interface unit allows multiple systems to be synched using one Sync Control unit.

Figure 1-1 shows the front view and Figure 1-2 shows the interior view of the Eaton Fixed Master Sync Control. Figure 1-3 shows the optional Sync Control Master Interface unit.

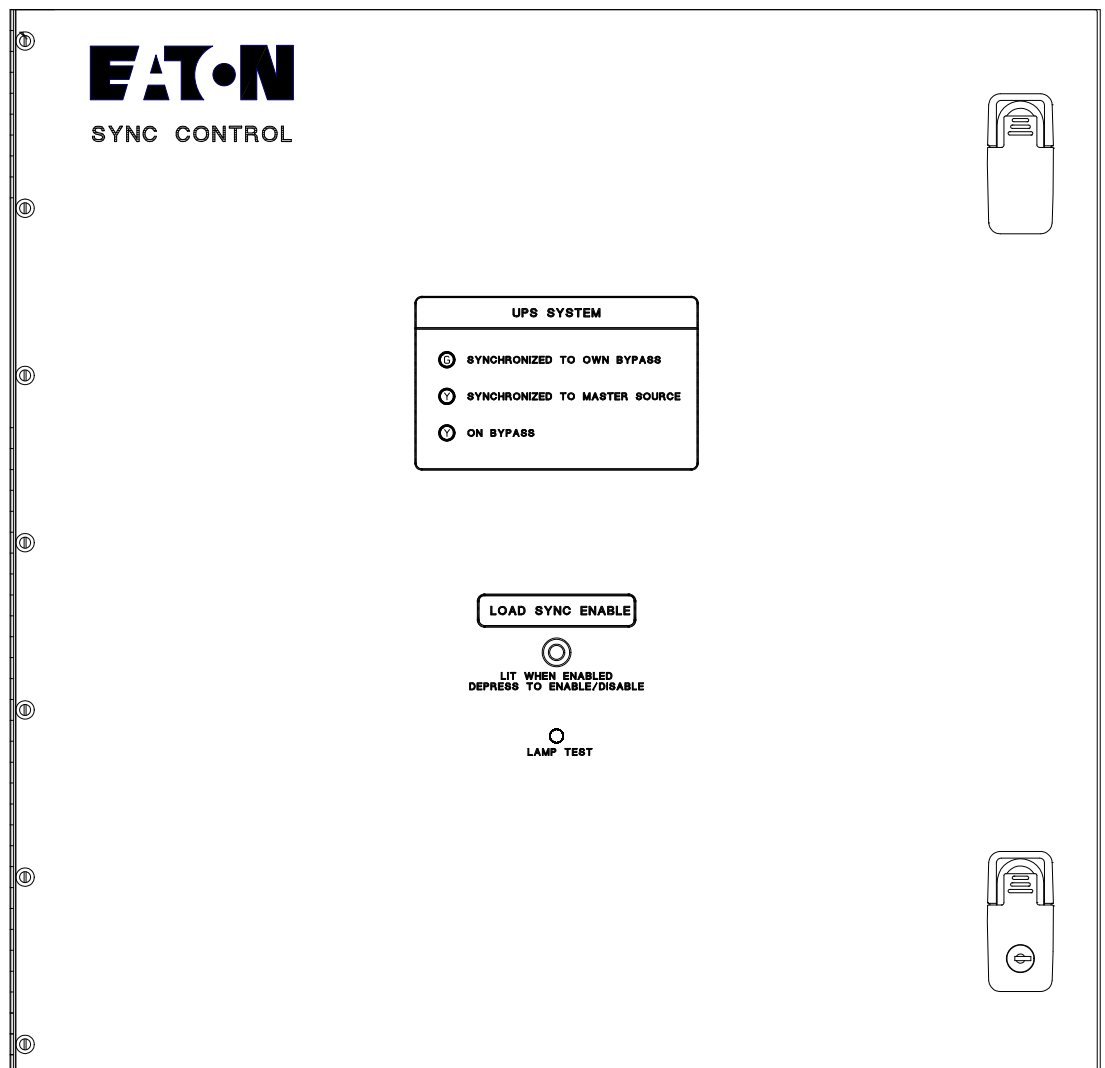

Figure 1-1. Eaton Fixed Master Sync Control

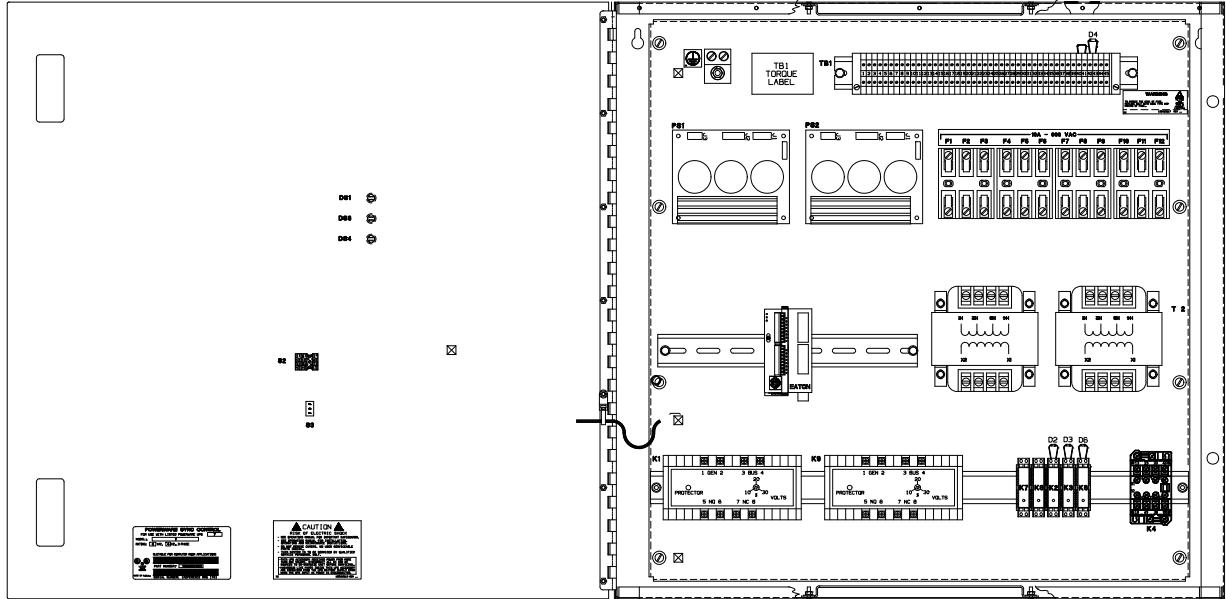

Figure 1-2. Eaton Fixed Master Sync Control with Door Open

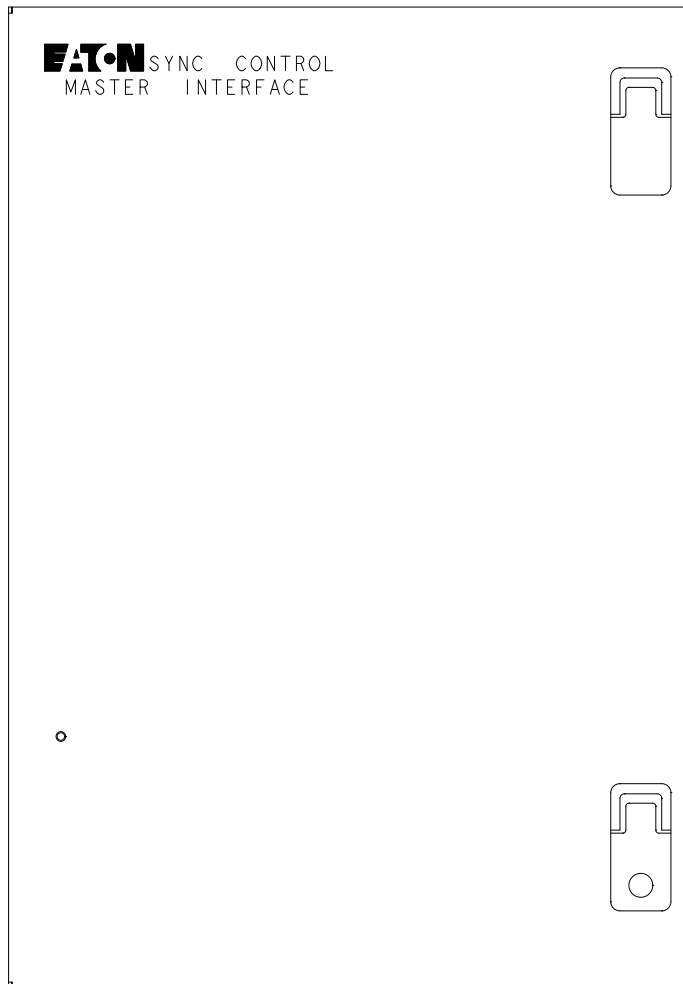



Figure 1-3. Eaton Sync Control Master Interface Panel

1.1 Conventions Used in This Manual

This manual uses these type conventions:

- **Bold type** highlights important concepts in discussions, key terms in procedures, and menu options, or represents a command or option that you enter at a prompt.
- *Italic type* highlights notes and new terms where they are defined.
- **Screen type** represents information that appears on the screen or LCD.

Icon	Description
	Information notes call attention to important features or instructions.
[Keys]	Brackets are used when referring to a specific key, such as [Enter] or [Ctrl].

In this manual, the term *UPS* refers only to the UPS cabinet and its internal elements. The term *UPS system* refers to the entire power protection system – the UPS cabinet, the battery cabinet, and options or accessories installed.

1.2 Safety Warnings

IMPORTANT SAFETY INSTRUCTIONS SAVE THESE INSTRUCTIONS

This manual contains important instructions that should be followed during installation and maintenance of the UPS and batteries. Please read all instructions before operating the equipment and save this manual for future reference.

The UPS cabinet is designed for industrial or computer room applications, and contains safety shields behind the doors. However, the UPS system is a sophisticated power system and should be handled with care.

DANGER



This UPS contains **LETHAL VOLTAGES**. All repairs and service should be performed by **AUTHORIZED SERVICE PERSONNEL ONLY**. There are **NO USER SERVICEABLE PARTS** inside the UPS.

WARNING



- The UPS system contains its own energy source (batteries). The output terminals may carry live voltage even when the UPS is disconnected from an AC source.
- To reduce the risk of fire or electric shock, install this UPS in a temperature and humidity controlled, indoor environment, free of conductive contaminants. Ambient temperature must not exceed 40°C (104°F). Do not operate near water or excessive humidity (95% maximum). The system is not intended for outdoor use.
- Ensure all power is disconnected before performing installation or service.

CAUTION



- Keep the UPS doors closed to ensure proper cooling airflow and to protect personnel from dangerous voltages inside the unit.
- Do not operate the UPS system close to gas or electric heat sources.
- The operating environment should be maintained within the parameters stated in this manual.
- Keep surroundings uncluttered, clean, and free from excess moisture.
- Observe all DANGER, CAUTION, and WARNING notices affixed to the inside and outside of the equipment.

1.3 For More Information

Refer to the following manuals for additional information:

- Eaton™ 9315 30-500 kVA UPS Installation and Operation Manual
- Eaton™ 9315 750 kVA UPS Installation and Operation Manual
- Eaton™ 9390 UPS (40–80 kVA) Installation and Operation Manual
- Eaton™ 9390 UPS (100–160 kVA) Installation and Operation Manual
- Power Xpert™ 9395 UPS (225–275 kVA) Installation and Operation Manual
- Power Xpert™ 9395 Plus 1 UPS (225–275 kVA) Installation and Operation Manual
- Power Xpert™ 9395 UPS (300 kVA) Installation and Operation Manual
- Power Xpert™ 9395 550/275 UPS (225–550 kVA) Installation and Operation Manual
- Power Xpert™ 9395 UPS and Plus 1 UPS (450–550 kVA) Installation and Operation Manual
- Power Xpert™ 9395 UPS and Plus 1 UPS (650–825 kVA) Installation and Operation Manual
- Power Xpert™ 9395 UPS (1000–1100 kVA) Installation and Operation Manual

These manuals describe:

- UPS cabinet, optional components, and accessory installation instructions, including site preparation, planning for installation, and wiring and safety information. Detailed illustrations of cabinets and optional accessories with dimensional and connection point drawings are provided.
- UPS operation, including UPS cabinet controls, functions of the UPS, standard features and optional accessories, procedures for starting and stopping the UPS, and information about maintenance and responding to system events.
- Communication capabilities of the UPS system.

Visit www.eaton.com/powerquality or contact Eaton service representative for information on how to obtain copies of these manuals.

1.4 Getting Help

If help is needed with any of the following:

- Scheduling initial startup
- Regional locations and telephone numbers
- A question about any of the information in this manual
- A question this manual does not answer

Please call the Help Desk at:

United States:	1-800-843-9433 or 1-919-870-3028
Canada:	1-800-461-9166 ext 260
All other countries:	Call your local service representative

Chapter 2

Installation Plan and Unpacking

The Eaton Fixed Master Sync Control is shipped as a separate item and can be mounted on any surface that can safely bear its weight. See paragraph 2.2 for weight, dimensions, and wiring preparation.

2.1 Creating an Installation Plan

Before installing the UPS system, read and understand how this manual applies to the system being installed. Use the procedures and illustrations in the following chapters to create a logical plan for installing the system.



NOTE Startup and operational checks must be performed by an authorized Eaton Customer Service Engineer, or the warranty terms as specified on page 5-1 become void. This service is offered as part of the sales contract for the UPS. Contact service in advance (usually a two-week notice is required) to reserve a preferred startup date.

2.2 Preparing the Site

For the Eaton Fixed Master Sync Control to operate at peak efficiency, the installation site should meet the environmental parameters outlined in the applicable Eaton 9315, Eaton 9390 or Power Xpert 9395 UPS installation and operation manual listed in paragraph 1.3.

2.2.1 Environmental and Installation Considerations

The life of the Eaton Fixed Master Sync Control is adversely affected if the system is not installed in a temperature and humidity controlled indoor area free of conductive contaminants.

Failure to follow guidelines may void your warranty.

The UPS equipment operating environment must meet the weight requirements shown in Table 2-1 and the size requirements shown in Figure 2-1 and Figure 2-2. Dimensions are in millimeters (inches).

Table 2-1. Equipment Weight

Model	Weight kg (lb)	
	Shipping	Installed
Eaton Fixed Master Sync Control	45.4 (100)	36.3 (80)
Eaton Master Interface	17.25 (38)	15.0 (33)

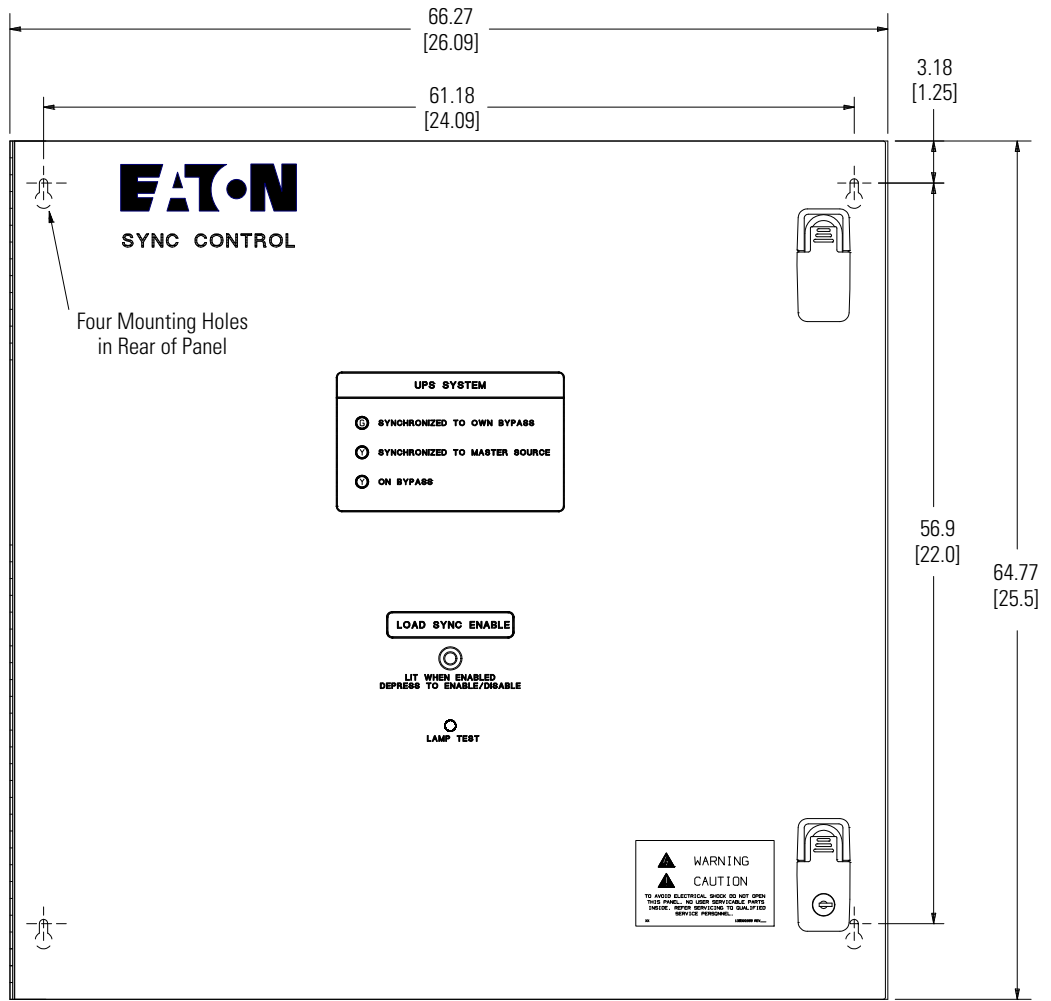

FRONT VIEW

Dimensions are in millimeters [inches].

Figure 2-1. Eaton Fixed Master Sync Control Dimensions – Front View

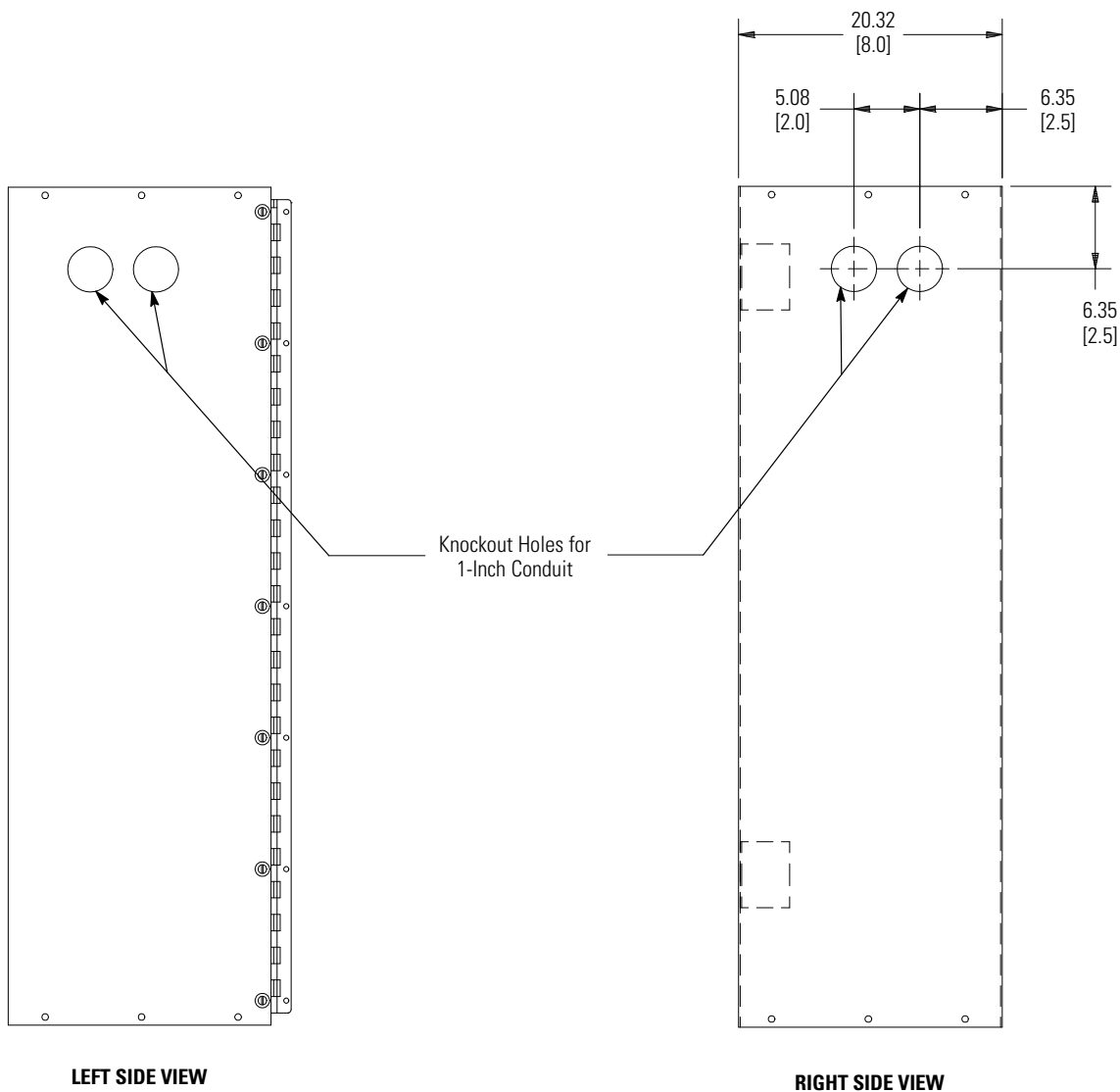

Dimensions are in millimeters [inches].

Figure 2-2. Eaton Fixed Master Sync Control Dimensions – Side Views

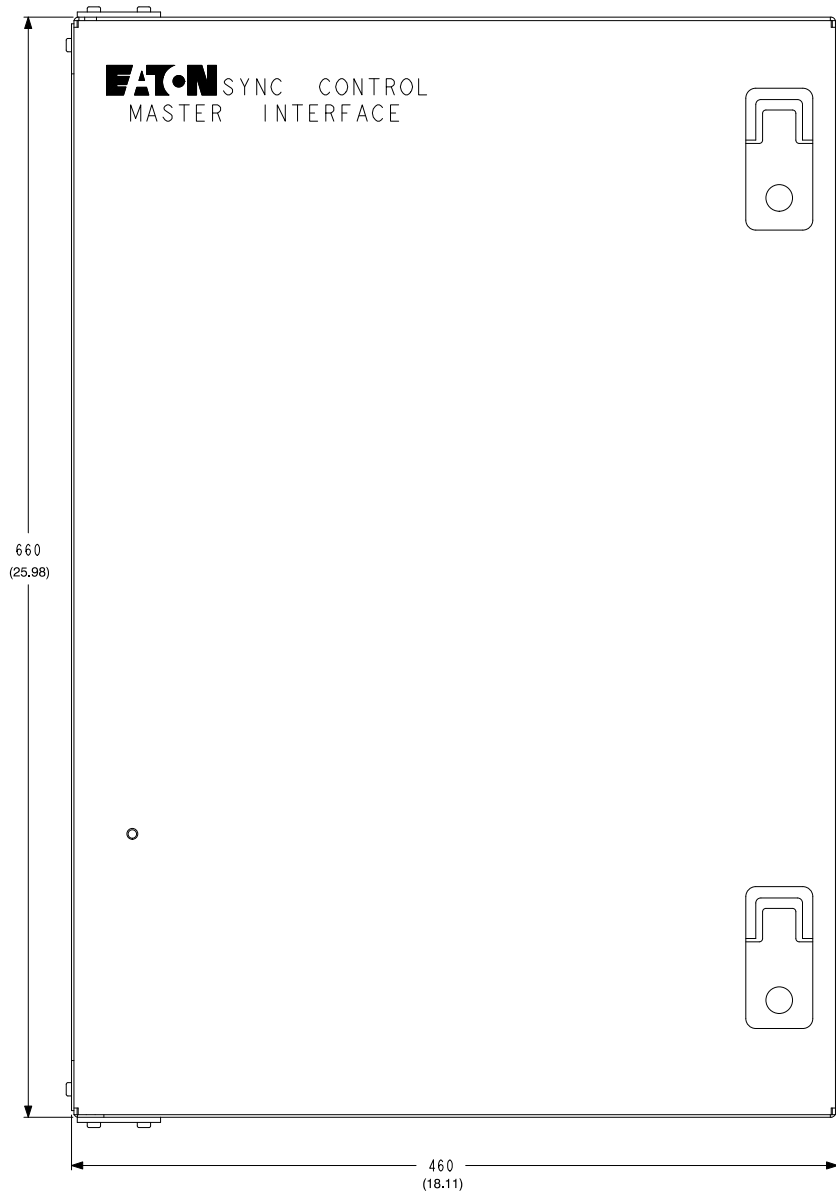

DIMENSIONS ARE IN MILLIMETERS [INCHES]

Figure 2-3. Eaton Master Interface Enclosure Dimensions - Front View

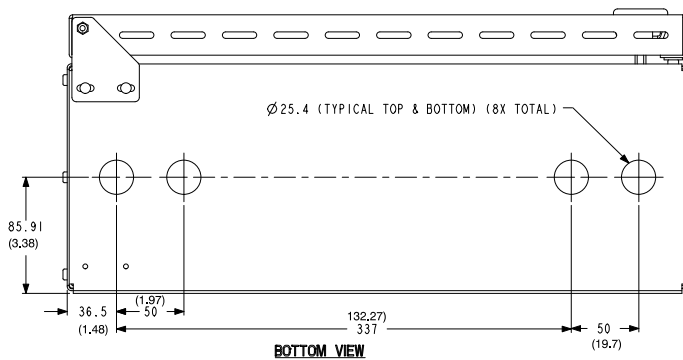
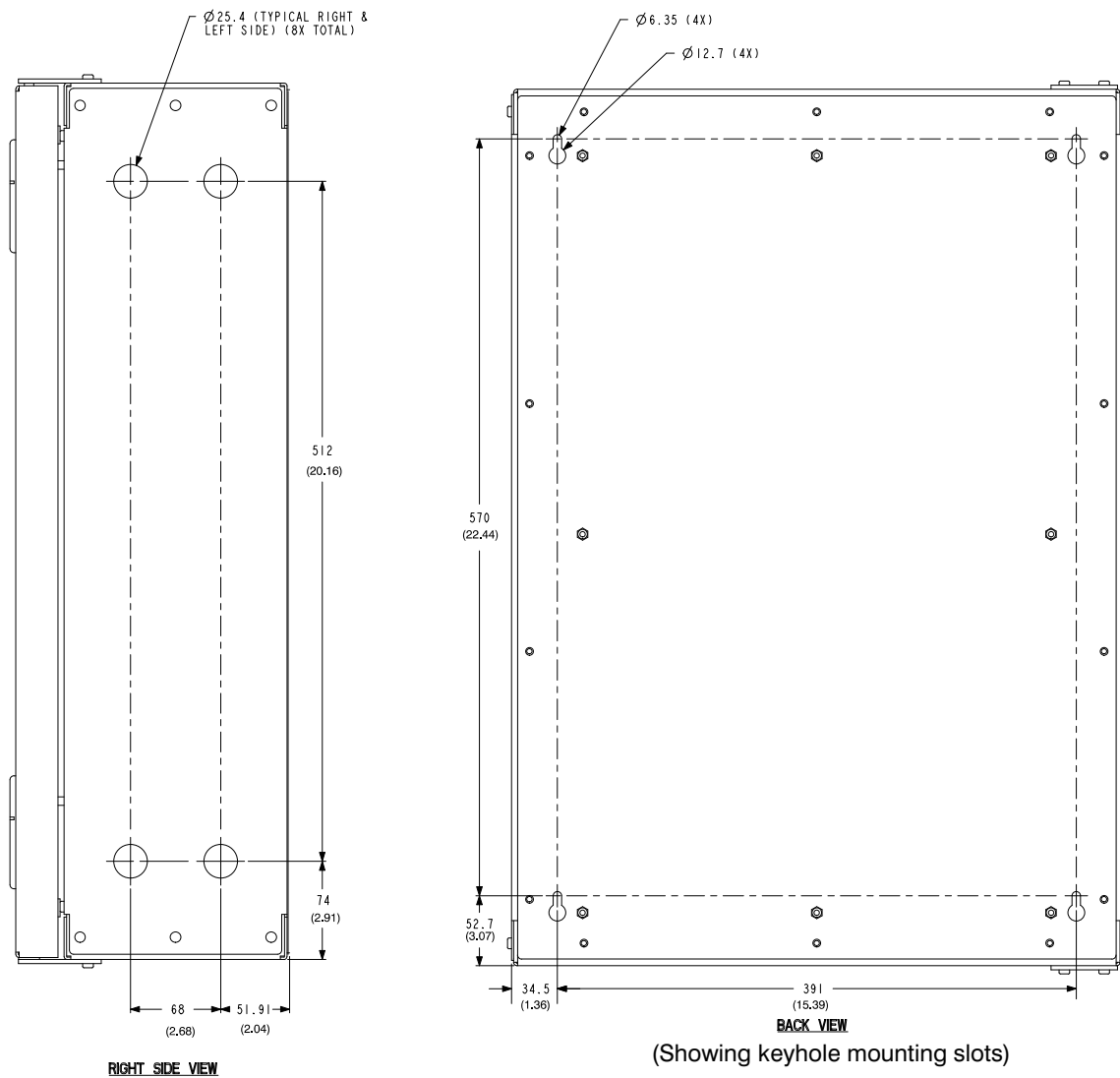

DIMENSIONS ARE IN MILLIMETERS [INCHES]

Figure 2-4. Eaton Master Interface Enclosure Dimensions - Side, Rear, and Bottom Views

2.2.2 Eaton Fixed Master Sync Control and Master Interface Wiring Preparation

Read and understand the following notes while planning and performing the installation:

- Refer to national and local electrical codes for acceptable external wiring practices.
- Material and labor for external wiring requirements are to be provided by designated personnel.
- For external wiring, use 90°C copper wire with a minimum insulation rating of 600V. If wire is run in an ambient temperature greater than 30°C, higher temperature wire and/or larger size wire may be necessary. See the applicable wiring information in Table for the Eaton 9315 UPS, Table 3-7 on page 3-16 for the Eaton 9390 UPS, and the applicable wiring information in Table 3-8 on page 3-20 for the Power Xpert 9395 UPS.
- Use 14 AWG wiring with a minimum insulation rating of 600V for interconnections between the Eaton Fixed Master Sync Control, the Master Interface unit, the UPS, and the customer remote monitoring system.
- Use Class 1 wiring methods (as defined by the NEC®) for interface wiring up to 30V. The wire should be rated at 24V, 1A minimum.
- Use Class 2 wiring methods (as defined by the NEC) for interface wiring from 30 to 600V. The wire should be rated at 600V, 1A minimum and 12 AWG maximum.
- Sync Control dry contacts are rated at 5–30 Vdc/250 Vac at 2A per contact (maximum load).
- Conduit must be used when installing external wiring between the Eaton Fixed Master Sync Control, Master Interface, and the UPS.
- The Eaton Fixed Master Sync Control can be installed up to a maximum of 152.4m (500 ft) from the UPS system.

CAUTION



When connecting the bypass and load voltage from another model UPS to an Eaton 9390 UPS or Power Xpert 9395 UPS using the Eaton Fixed Master Sync Control accessory, use Phase A, Phase B, and Neutral connections from the other UPS. DO NOT connect the other model UPS Phase C bypass and load voltage to the Sync Control connection point when connecting to an Eaton 9390 or Power Xpert 9395 UPS.

2.3 Inspecting and Unpacking the Eaton Fixed Master Sync Control or Master Interface

The unit arrives covered with protective packaging material.

1. Carefully inspect the outer packaging for evidence of damage during transit.

CAUTION



Do not install a damaged cabinet. Report any damage to the carrier and contact Eaton service representative immediately.

2. Remove the protective cardboard covering from the Eaton Fixed Master Sync Control or Master Interface unit by cutting where indicated using a knife blade no longer than 25 mm (1").
3. Remove the plastic bag and foam packing material, and discard or recycle them in a responsible manner.



WARNING

- Only qualified service personnel (such as a licensed electrician) shall perform the electrical installation. Risk of electrical shock.
- Shut down all sources of power to the Eaton 9315, Eaton 9390 UPS or Power Xpert 9395 UPS system before connecting the control wiring to the Eaton Fixed Master Sync Control enclosure and UPS. Hazardous voltages exist inside the UPS and in the Eaton Fixed Master Sync Control enclosure. Check all terminal conductors with a known serviceable voltmeter before connecting the wiring.

When the Eaton Fixed Master Sync Control has been moved to its installed location, unpacked, and inspected, it is ready for installation and wiring.

Use the applicable procedure from the following list to install the Eaton Fixed Master Sync Control to the UPS:

- For an Eaton 9315 UPS, proceed to paragraph 3.2.
- For an Eaton 9390 UPS, proceed to paragraph 3.3.
- For a Power Xpert 9395 UPS, proceed to paragraph 3.4.

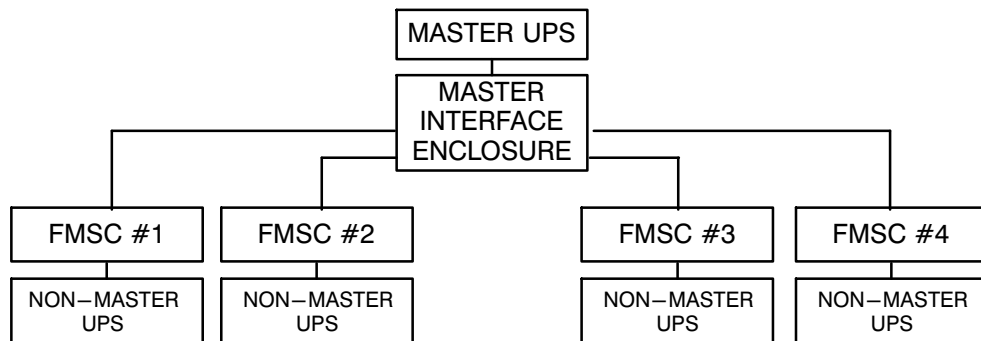

Figure 3-1. Fixed Master Sync Control with Master Interface Enclosure Functional Diagram

3.1 Installation

Grounding Connection

TB1 (See Figure 3-3 for detail)

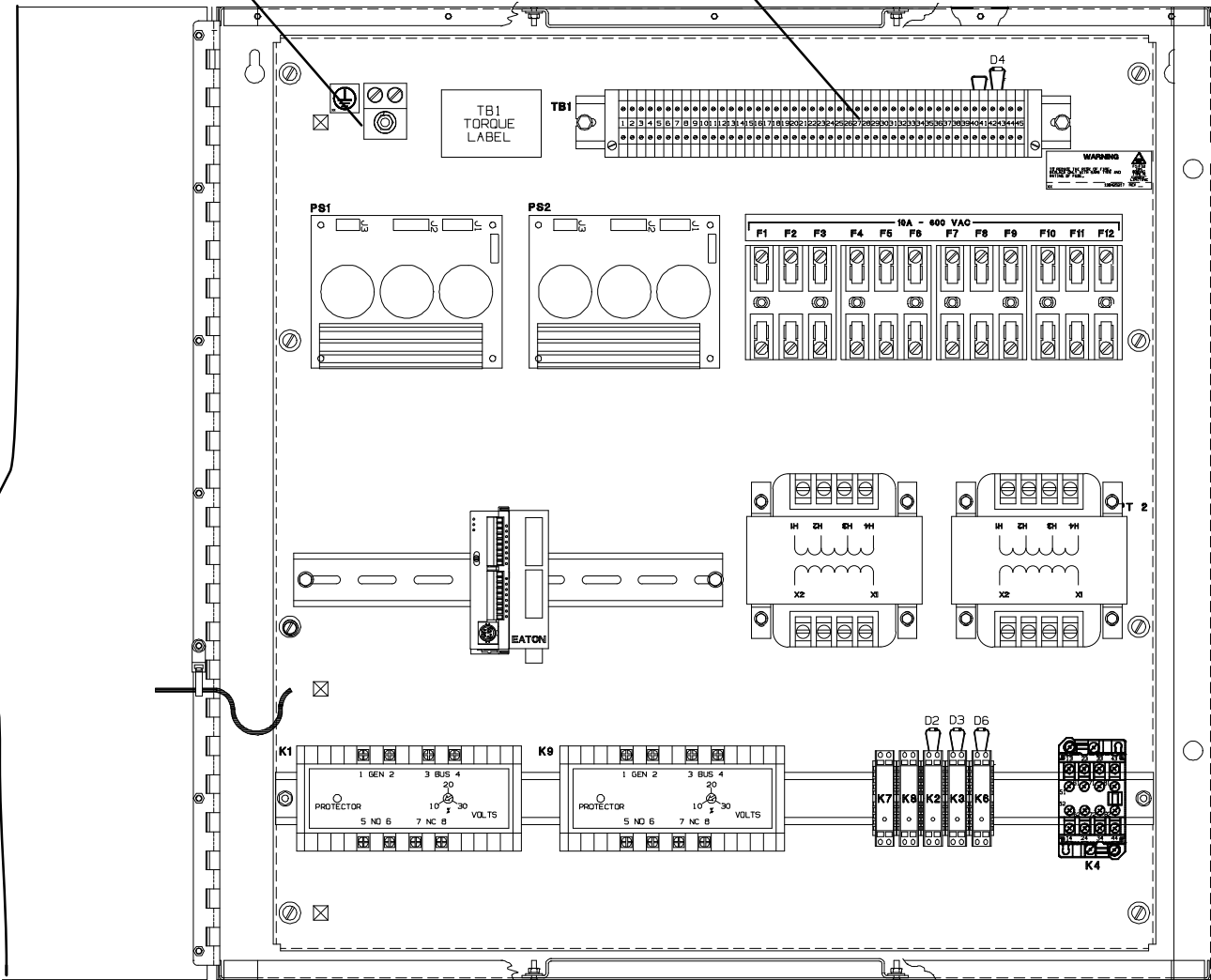
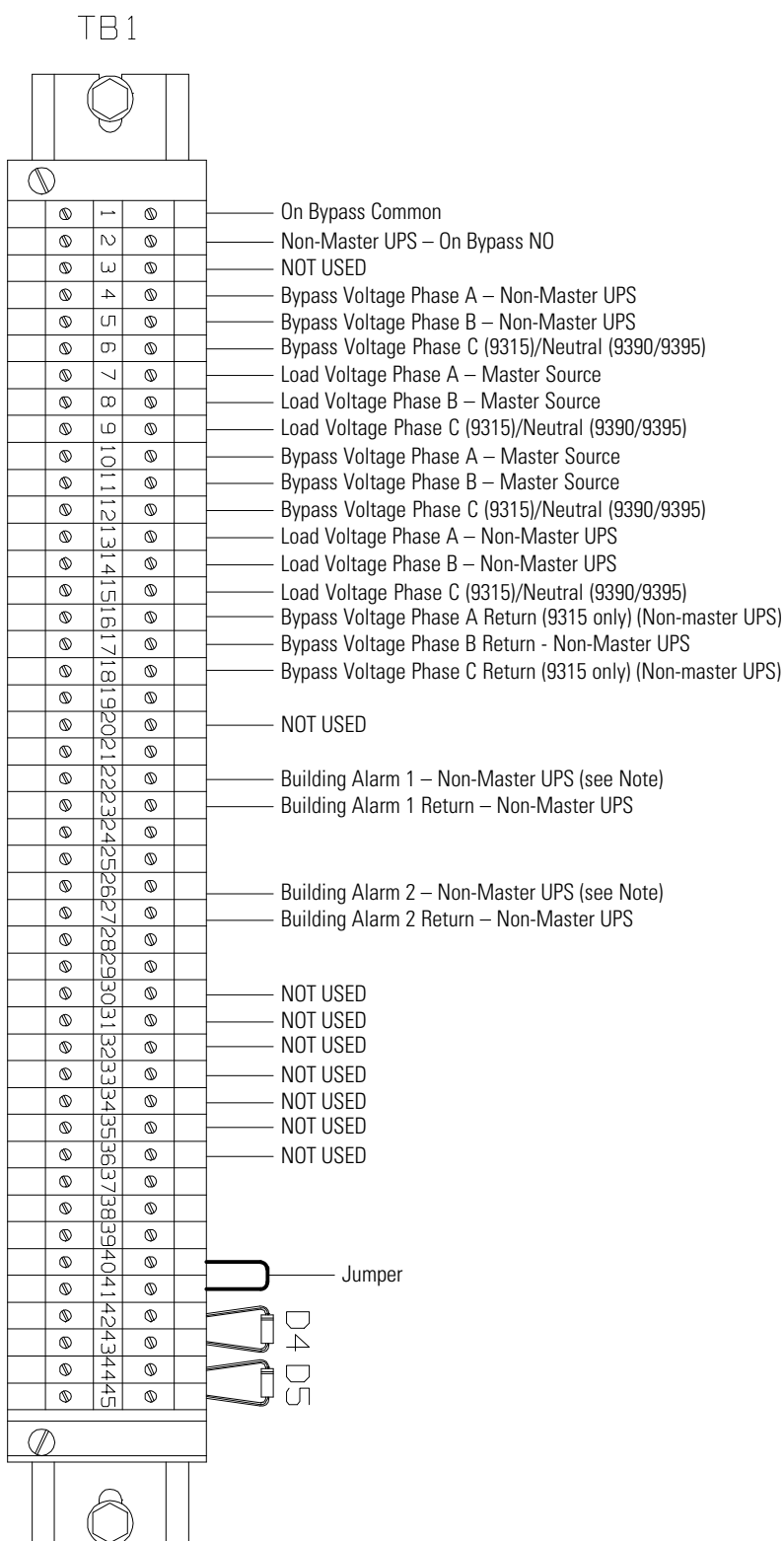

Figure 3-2. Typical Eaton Fixed Master Sync Control Control Wiring Termination Locations



NOTE If a Building Alarm is being used for another purpose, any unused building alarm on the 9315/9390/9395 UPS can be used for the Sync Control.

Figure 3-3. Eaton Fixed Master Sync Control TB1 Terminal Block Detail

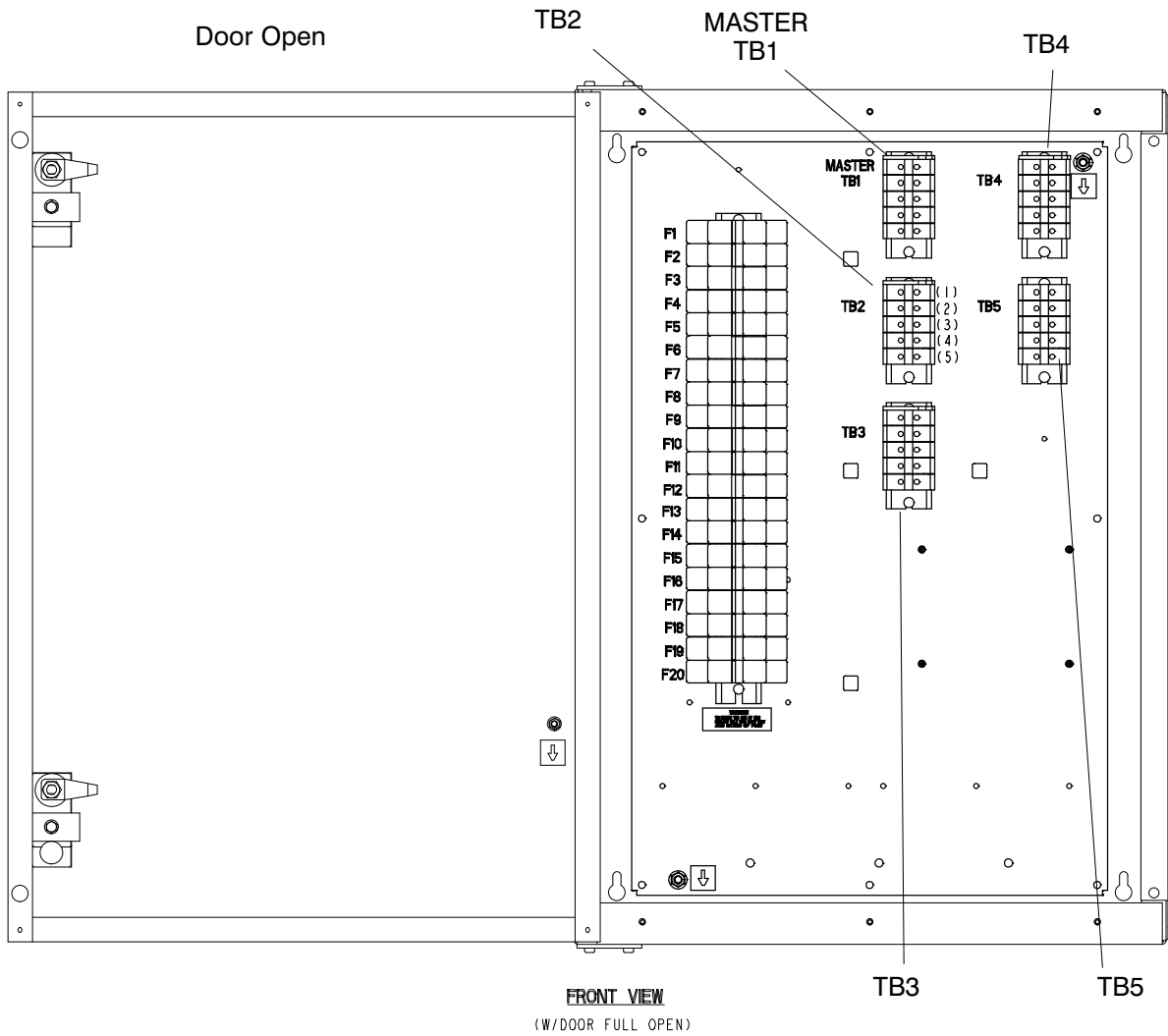

Figure 3-4. Typical Control Wiring Termination Locations for Eaton Master Interface Enclosure



NOTE The Master Interface enclosure unit wiring requirements are specified at the time of installation.

3.2 Installation and Wiring with an Eaton 9315 UPS



NOTE When installing wiring connections, conduit must be installed between the Eaton Fixed Master Sync Control and the UPS cabinet. Conduit also must be installed between the Eaton Fixed Master Sync Control and the customer's remote monitoring system.

To install and wire:

1. Install the Eaton Fixed Master Sync Control panel to the selected mounting location.

See Figure 2-1 on page 2-2 for mounting hole dimensions and Figure 2-2 on page 2-3 for conduit entrance locations.

2. Unfasten the front door latches and swing the door open.
3. Complete all control wiring interconnections using Table 3-1 through Table 3-4 for wiring requirements.

Figure 3-2 shows the Eaton Fixed Master Sync Control TB1 terminal block and ground terminal locations. Figure 3-3 shows the TB1 terminal block wiring detail.

Figure 3-6 through Figure 3-10 show the typical locations of the UPS TB3, and TB6. Figure 3-5 shows the TB6 detail.

Refer to the applicable Eaton 9315 UPS Installation and Operation Manual listed in paragraph 1.3 on page 1-4 for UPS cabinet terminal locations and assignments, termination requirements, conduit landing locations, and terminal access instructions.

4. Verify the jumper is installed between Sync Control terminal TB1-40 and TB1-41 (see Figure 3-3).
5. When all wiring is complete, close the door and secure the latch.

CAUTION



When connecting the bypass and load voltage from another model UPS to a Eaton 9315 UPS using the Eaton Fixed Master Sync Control accessory, use Phase A, Phase B and Phase C connections from the other UPS.

Table 3-1. Eaton 9315 UPS System Control Wiring Interconnections for Single Module 30-500 kVA UPS

From Non-Master UPS (9315)	To Sync Control	Function	Note
TB6-3	TB1-1	UPS ON BYPASS	14 AWG Twist Together
TB6-4	TB1-2		
TB6-5	TB1-4	BYPASS VOLTAGE	14 AWG Twist Together
TB6-6	TB1-5		
TB6-7	TB1-6		
TB6-11	TB1-13	LOAD VOLTAGE	14 AWG Twist Together
TB6-12	TB1-14		
TB6-13	TB1-15		
TB6-8	TB1-16	REFERENCE VOLTAGE	14 AWG Twist Together
TB6-9	TB1-17		
TB6-10	TB1-18		
TB1-9	TB1-22	BYPASS DISABLED	14 AWG Twist Together
TB1-10	TB1-23		
TB1-7	TB1-26	SYNC TROUBLE	14 AWG Twist Together
TB1-8	TB1-27		
Remove the following jumpers, if connected, from UPS module terminal block TB6 when installing the Sync Control		FROM TB6-5 TB6-6 TB6-7	TO TB6-8 TB6-9 TB6-10

Table 3-2. Eaton 9315 UPS System Control Wiring Interconnections for 750 kVA UPS

From Non-Master UPS (9315)	To Sync Control	Function	Note
CUSTTB1-1	TB1-1	UPS ON BYPASS (24 Vdc)	14 AWG Twist Together
CUSTTB1-2	TB1-2		
CUSTTB2-1	TB1-4	BYPASS VOLTAGE	14 AWG Twist Together
CUSTTB2-2	TB1-5		
CUSTTB2-5	TB1-13		
CUSTTB2-6	TB1-14	LOAD VOLTAGE	14 AWG Twist Together
CUSTTB2-3	TB1-16	REFERENCE VOLTAGE (480 Vac)	14 AWG Twist Together
CUSTTB2-4	TB1-17		
CUSTTB-6 (Located in Inverter Cabinet #2)	TB1-22	BYPASS DISABLED (24 Vdc)	14 AWG Twist Together
CUSTTB-7 (Located in Inverter Cabinet #2)	TB1-23		
CUSTP2-4	TB1-26	SYNC TROUBLE (24 Vdc)	14 AWG Twist Together
CUSTP2-5	TB1-27		
Remove the following jumpers, if connected, from UPS module terminal block TB6 when installing the Sync Control		FROM CUSTTB2-1 CUSTTB2-2	TO CUSTTB2-3 CUSTTB2-4

Table 3-3. Eaton 9315 UPS System Control Wiring Interconnections for Single Module 30-500 kVA UPS

From Master UPS (9315)	To Sync Control	Function	Note
TB6-5	TB1-10	BYPASS VOLTAGE	14 AWG Twist Together
TB6-6	TB1-11		
TB6-11	TB1-7	LOAD VOLTAGE	14 AWG Twist Together
TB6-12	TB1-8		
TB6-13	TB1-9		
Install the following jumpers, if not connected, from UPS module terminal block TB6 when installing the Sync Control		FROM TB6-5 TB6-6 TB6-7	TO TB6-8 TB6-9 TB6-10

Table 3-4. Eaton 9315 UPS System Control Wiring Interconnections for 750 kVA UPS

From Master UPS (9315)	To Sync Control	Function	Note
CUSTTB2-1	TB1-10	BYPASS VOLTAGE	14 AWG Twist Together
CUSTTB2-2	TB1-11		
CUSTTB2-5	TB1-7	LOAD VOLTAGE	14 AWG Twist Together
CUSTTB2-6	TB1-8		
CUSTTB2-7*	TB1-9		
*Requires installation of CK155011-100 to have 750 kVA module as the master for any other Eaton 9315 series system other than another 750 kVA unit.			
Remove the following jumpers, if connected, from UPS module terminal block TB6 when installing the Sync Control		FROM CUSTTB2-1 CUSTTB2-2	TO CUSTTB2-3 CUSTTB2-4



NOTE If connecting multiple non-master sources to a single master source, the Master Interface Enclosure must used and wired as shown in the following table. A maximum of four non-master units can be connected to the Master Interface Enclosure. One Fixed Master Sync Control should be used per non-master unit.

Table 3-5. Master Interface Enclosure to Fixed Master Sync Control Connections

From Master Interface Enclosure	To FMSC #1	Wire Size (Remarks)	Description
TB2-1	TB1-7		
TB2-2	TB1-8	14 AWG Twist Together	Master Load Voltage
TB2-3	TB1-9		
TB2-4	TB1-10	14 AWG Twist Together	Master Bypass Voltage
TB2-5	TB1-11		
From Master Interface Enclosure	To FMSC #2	Wire Size (Remarks)	Description
TB3-1	TB1-7		
TB3-2	TB1-8	14 AWG Twist Together	Master Load Voltage
TB3-3	TB1-9		
TB3-4	TB1-10	14 AWG Twist Together	Master Bypass Voltage
TB3-5	TB1-11		
From Master Interface Enclosure	To FMSC #3	Wire Size (Remarks)	Description
TB4-1	TB1-7		
TB4-2	TB1-8	14 AWG Twist Together	Master Load Voltage
TB4-3	TB1-9		
TB4-4	TB1-10	14 AWG Twist Together	Master Bypass Voltage
TB4-5	TB1-11		
From Master Interface Enclosure	To FMSC #4	Wire Size (Remarks)	Description
TB5-1	TB1-7		
TB5-2	TB1-8	14 AWG Twist Together	Master Load Voltage
TB5-3	TB1-9		
TB5-4	TB1-10	14 AWG Twist Together	Master Bypass Voltage
TB5-5	TB1-11		

Table 3-6. Master Interface Enclosure to UPS Control Connections

From Master Interface Enclosure	To 9315-500 UPS	Wire Size (Remarks)	Description
MASTER TB1-1	TB6-11	14 AWG Twist Together	Master Load Voltage
MASTER TB1-2	TB6-12		
MASTER TB1-3	TB6-13		
MASTER TB1-4	TB1-5	14 AWG Twist Together	Master Bypass Voltage
MASTER TB1-5	TB1-6		
From Master Interface Enclosure	To 9315-750 UPS	Wire Size (Remarks)	Description
MASTER TB1-1	CUSTTB2-5	14 AWG Twist Together	Master Load Voltage
MASTER TB1-2	CUSTTB2-6		
MASTER TB1-3	CUSTTB2-7		
MASTER TB1-4	CUSTTB2-1	14 AWG Twist Together	Master Bypass Voltage
MASTER TB1-5	CUSTTB2-2		
From Master Interface Enclosure	To 9390 UPS	Wire Size (Remarks)	Description
MASTER TB1-1	TB6-4	14 AWG Twist Together	Master Load Voltage
MASTER TB1-2	TB6-5		
MASTER TB1-3	TB6-6		
MASTER TB1-4	TB6-1	14 AWG Twist Together	Master Bypass Voltage
MASTER TB1-5	TB6-2		
From Master Interface Enclosure	To 9395 UPS	Wire Size (Remarks)	Description
MASTER TB1-1	TB6-4	14 AWG Twist Together	Master Load Voltage
MASTER TB1-2	TB6-5		
MASTER TB1-3	TB6-6		
MASTER TB1-4	TB6-1	14 AWG Twist Together	Master Bypass Voltage
MASTER TB1-5	TB6-2		

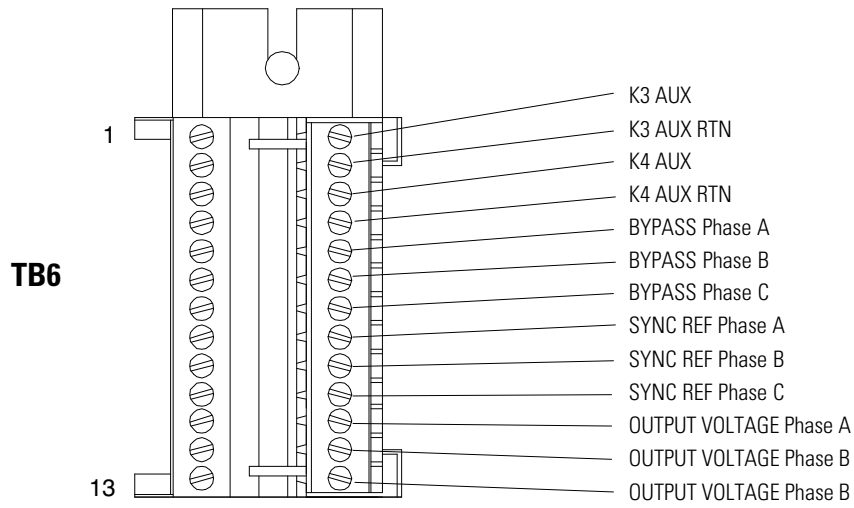

Figure 3-5. TB6 Terminal Block Detail (All Systems)

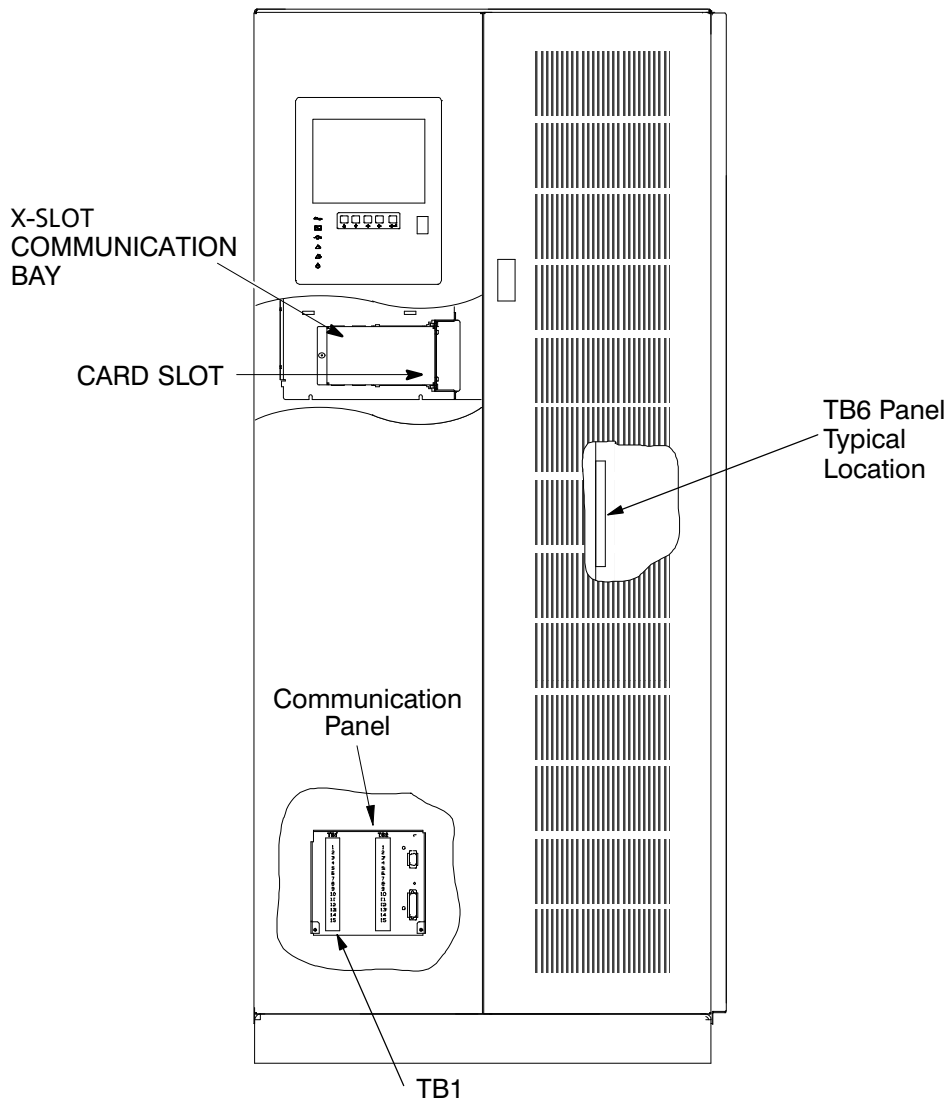

Figure 3-6. Fixed Master Sync Control Interface Location for 30-80 kVA Single Module 9315 UPS System

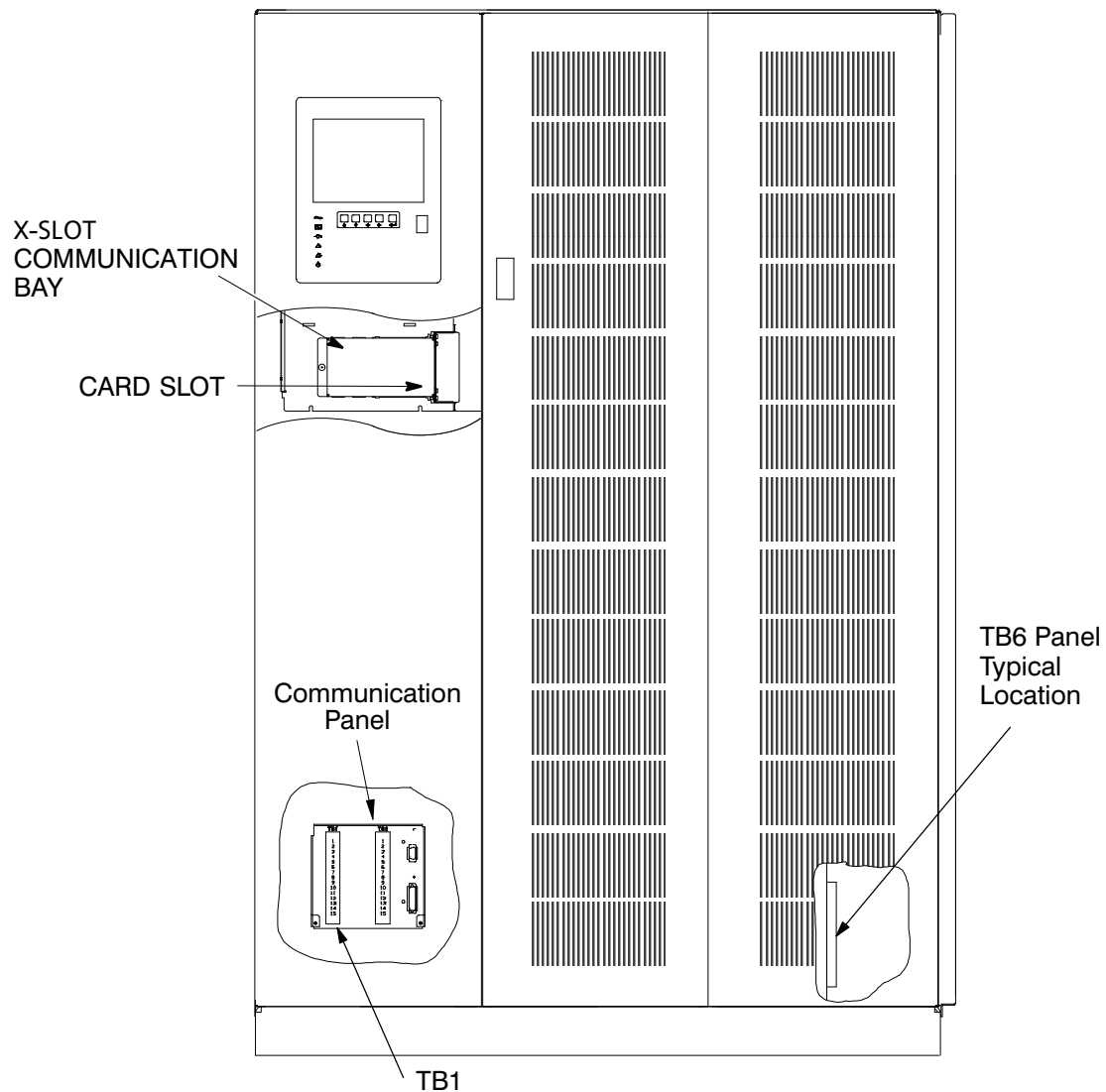

Figure 3-7. Fixed Master Sync Control Interface Location for 100-160 kVA Single Module 9315 UPS System

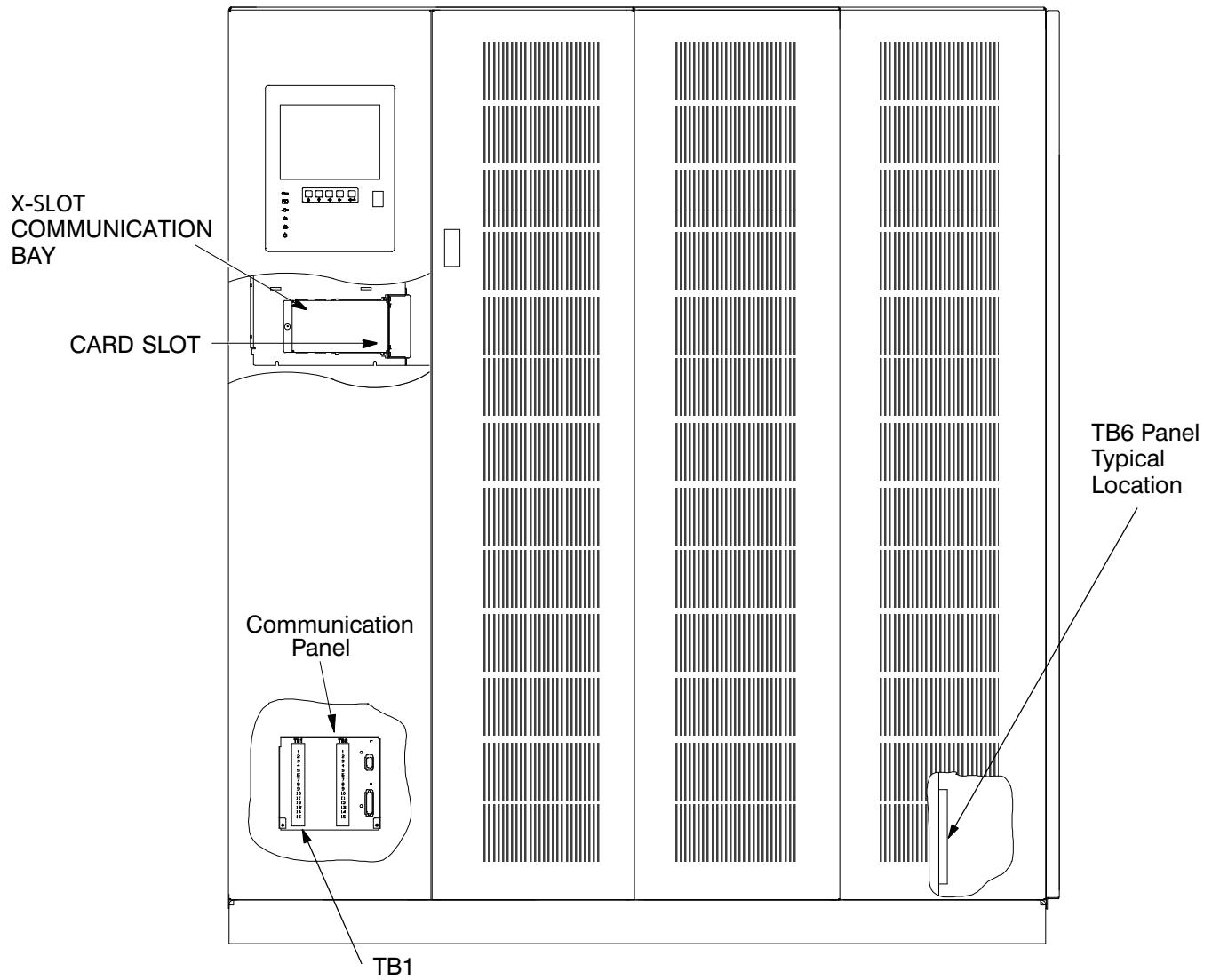

Figure 3-8. Fixed Master Sync Control Interface Locations for 200-300 kVA Single Module 9315 UPS System

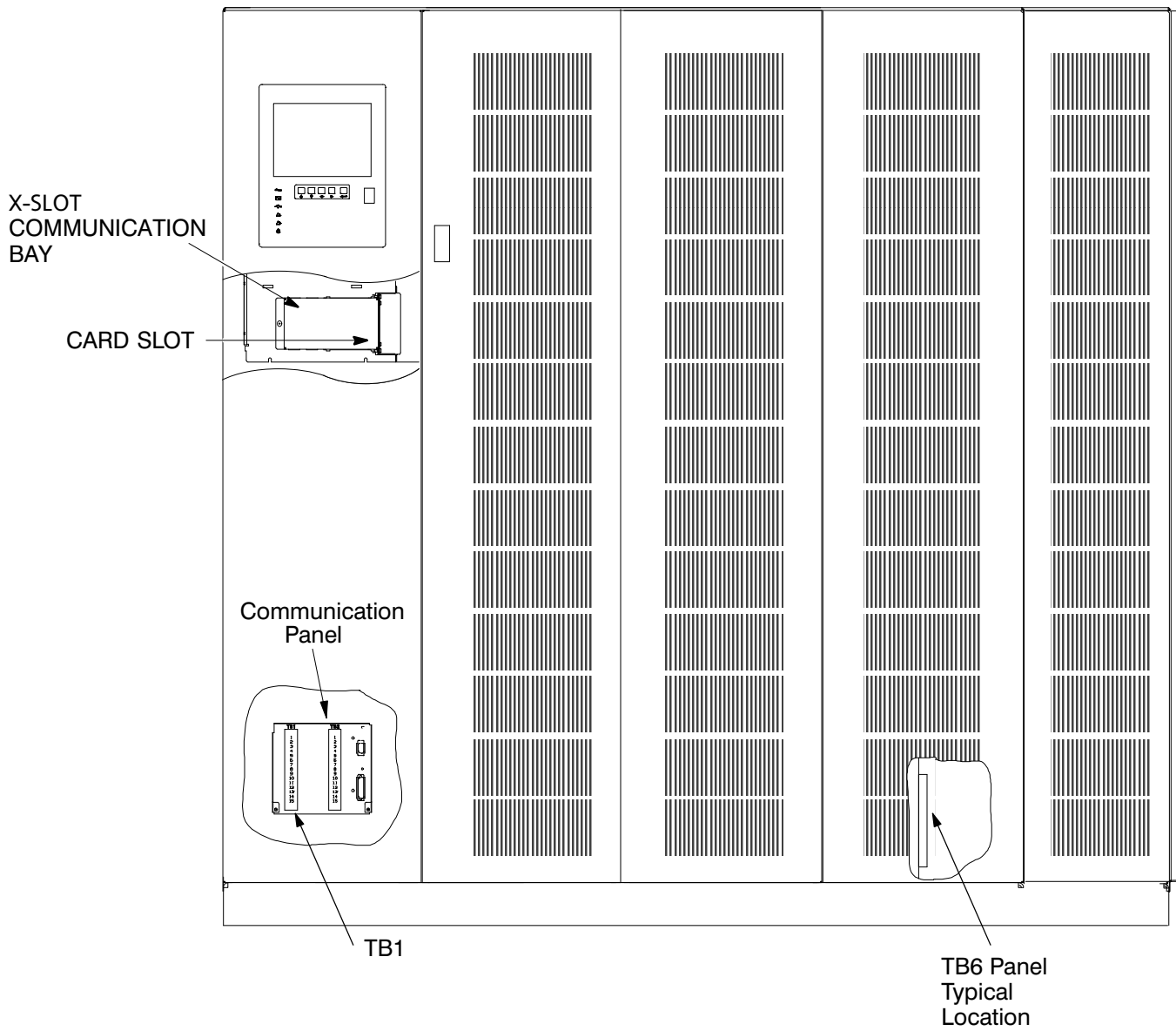
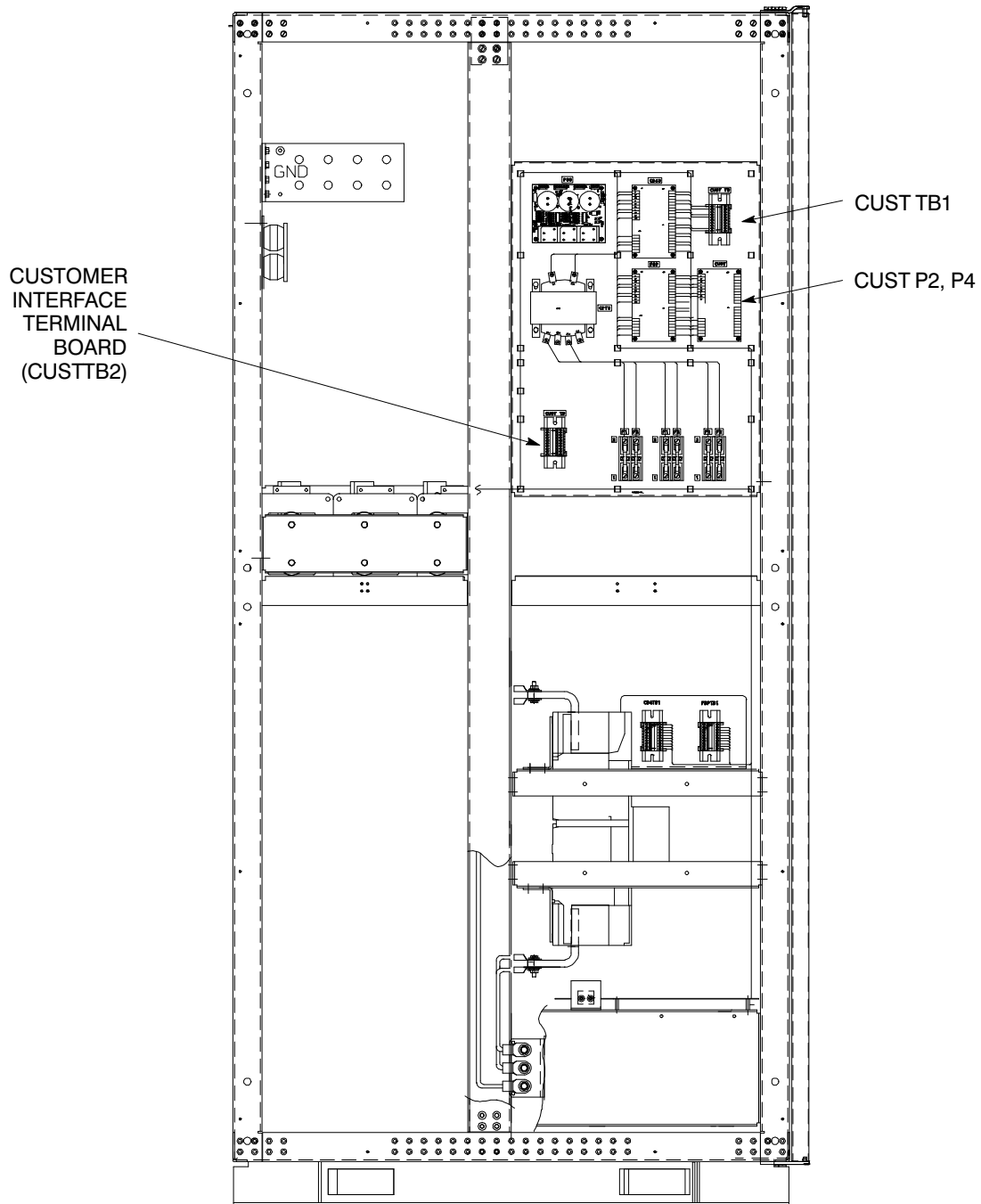

Figure 3-9. Fixed Master Sync Control Interface Location for 400-500 kVA Single Module 9315 UPS System



Left Side View, Reverse Transfer Cabinet (MBC)

Figure 3-10. Fixed Master Sync Control Interface Location for 750 kVA Single Module 9315 UPS System

3.3 Installation and Wiring with an Eaton 9390 UPS



NOTE When installing wiring connections, conduit must be installed between the Eaton Fixed Master Sync Control and the UPS cabinet. Conduit also must be installed between the Eaton Fixed Master Sync Control and the customer's remote monitoring system.

To install and wire:

1. Install the Eaton Fixed Master Sync Control panel to the selected mounting location.

See Figure 2-1 on page 2-2 for mounting hole dimensions and Figure 2-2 on page 2-3 for conduit entrance locations.

2. Unfasten the front door latches and swing the door open.
3. Complete all control wiring interconnections using Table 3-7 for wiring requirements.

Figure 3-2 shows the Eaton Fixed Master Sync Control TB1 terminal block and ground terminal locations. Figure 3-3 shows the TB1 terminal block wiring detail.

Figure 3-11 and Figure 3-12 show the typical locations of the UPS TB1, TB2, and TB6 interconnect terminal blocks. Figure 3-13 shows the TB6 detail.

Refer to the applicable Eaton UPS Installation and Operation Manual listed in paragraph 1.3 on page 1-4 for UPS cabinet terminal locations and assignments, termination requirements, conduit landing locations, and terminal access instructions.

4. Verify the jumper is installed between Sync Control terminal TB1-40 and TB1-41 (see Figure 3-3).
5. When all wiring is complete, close the door and secure the latches.

CAUTION



When connecting the bypass and load voltage from another model UPS to an Eaton 9390 UPS using the Eaton Fixed Master Sync Control accessory, use Phase A, Phase B, and Neutral connections from the other UPS. DO NOT connect the other model UPS Phase C bypass and load voltage to the Sync Control connection point when connecting to an Eaton 9390 UPS.

Table 3-7. Eaton 9390 UPS System Control Wiring Interconnections

From Non-Master UPS (9390)	To Sync Control	Function	Note
TB6-1	TB1-4	Bypass Voltage	14 AWG Twist Together
TB6-2	TB1-5		
TB6-3	TB1-6		
TB6-4	TB1-13	Load Voltage	14 AWG Twist Together
TB6-5	TB1-14		
TB6-6	TB1-15		
TB6-7	—	NOT USED	—
TB6-8	—	NOT USED	—
TB6-9	TB1-17	Bypass Voltage Phase B Return	14 AWG
TB6-10	—	NOT USED	—
TB-10 (AS400 Relay Card)	TB1-1	On Bypass Common	14 AWG Twist Together
TB-11 (AS400 Relay Card)	TB1-2	On Bypass NO	
P5-5	TB1-22	Building Alarm 5 (Mini-CSB) (Transfer to Bypass Disable)	14 AWG Twist Together
P5-6	TB1-23	Building Alarm 5 Return	
P5-7	TB1-26	Building Alarm 6 (Mini-CSB) (Sync Control Trouble)	14 AWG Twist Together
P5-8	TB1-27	Building Alarm 6 Return	
From Master UPS (9390)	To Sync Control	Function	Note
TB6-1	TB1-10	Bypass Voltage	14 AWG Twist Together
TB6-2	TB1-11		
TB6-3	TB1-12		
TB6-4	TB1-7	Load Voltage	14 AWG Twist Together
TB6-5	TB1-8		
TB6-6	TB1-9		

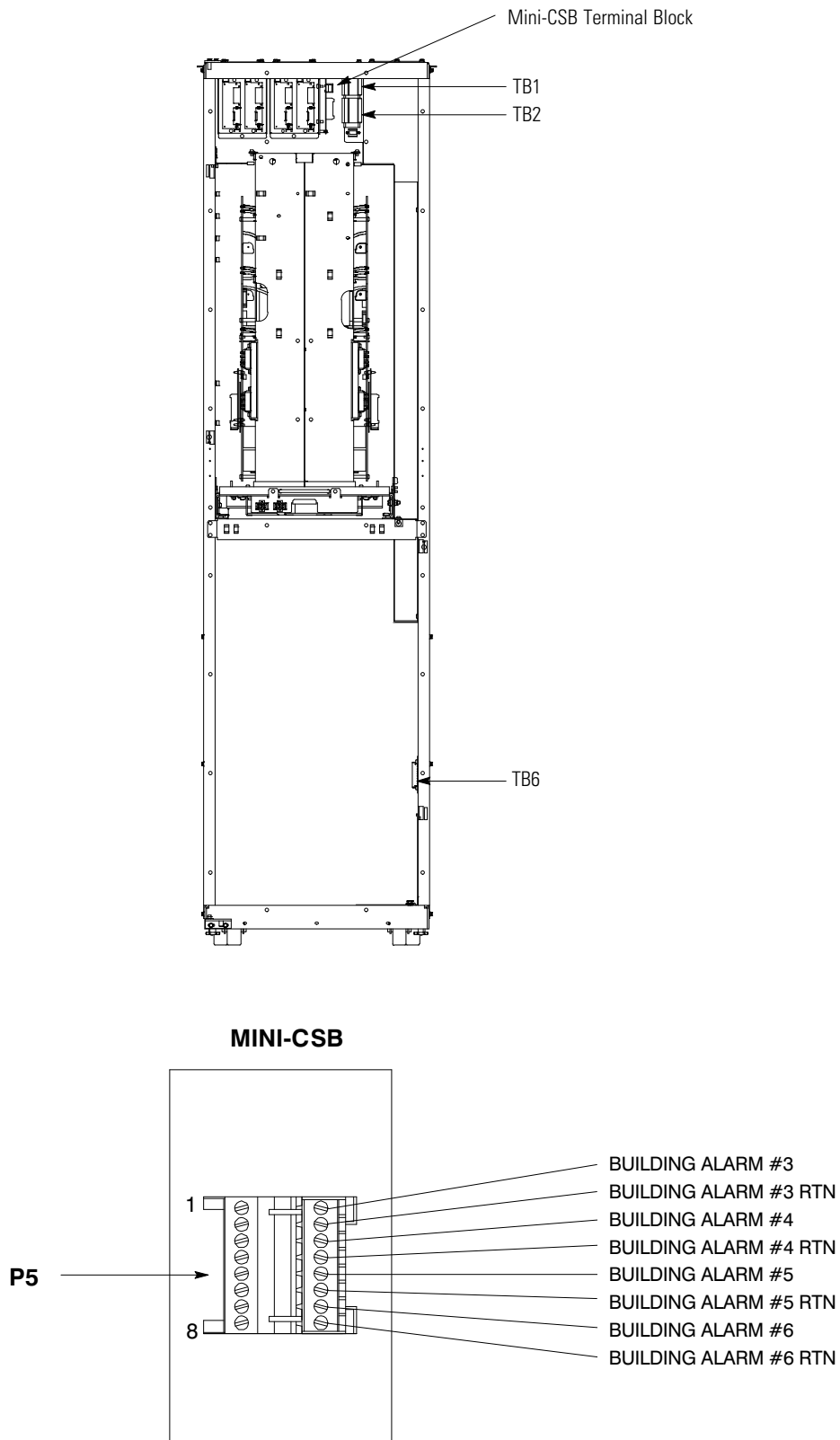

Figure 3-11. Eaton 9390 UPS (40–80 kVA) Interface Locations for Eaton Fixed Master Sync Control

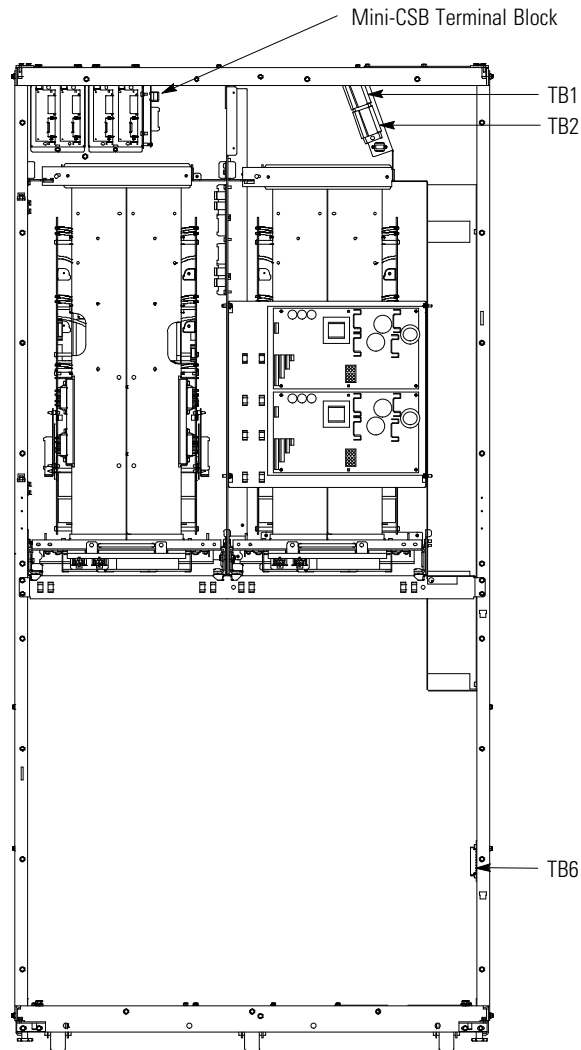

Figure 3-12. Eaton 9390 UPS (100–160 kVA) Interface Locations for Eaton Fixed Master Sync Control

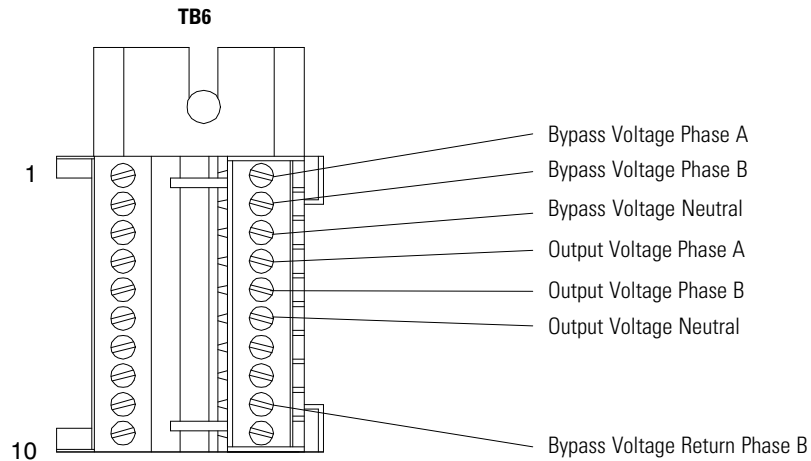

Figure 3-13. TB6 Terminal Block Detail

3.4 Installation and Wiring with an Power Xpert 9395 UPS



NOTE When installing wiring connections, conduit must be installed between the Eaton Fixed Master Sync Control and the UPS cabinet. Conduit also must be installed between the Eaton Fixed Master Sync Control and the customer's remote monitoring system.

To install and wire:

1. Install the Eaton Fixed Master Sync Control panel to the selected mounting location.

See Figure 2-1 on page 2-2 for mounting hole dimensions and Figure 2-2 on page 2-3 for conduit entrance locations.

2. Unfasten the front door latches and swing the door open.
3. Complete all control wiring interconnections using Table 3-8 for wiring requirements.

Figure 3-2 shows the Eaton Fixed Master Sync Control TB1 terminal block and ground terminal locations. Figure 3-3 shows the TB1 terminal block wiring detail.

Figure 3-15 through Figure 3-18 show the typical locations of the UPS TB3, TB6, and X-Slot® Relay Interface Card interconnect terminal blocks. Figure 3-14 shows the TB6 detail.

Refer to the applicable Power Xpert 9395 UPS Installation and Operation Manual listed in paragraph 1.3 on page 1-4 for UPS cabinet terminal locations and assignments, termination requirements, conduit landing locations, and terminal access instructions.



NOTE Complete the wiring to the X-Slot Relay Interface Card terminals before installing the cards in the Communication Bay in each of the UPS cabinets.

4. Route wires through the strain relief bushing and connect to the terminals on the X-Slot Relay Interface Card in each of the UPS cabinets (see Figure 3-19 and Figure 3-20).
5. Install the X-Slot Relay Interface Card into an open X-Slot communication bay on the front of the UPS (see Figure 3-15, Figure 3-16, Figure 3-17, or Figure 3-18). Refer to the applicable Power Xpert 9395 UPS Installation and Operation Manual listed in paragraph 1.3 on page 1-4 for UPS cabinet access instructions.
6. Verify the jumper is installed between Sync Control terminal TB1-40 and TB1-41 (see Figure 3-3).
7. When all wiring is complete, close the door and secure the latch.

CAUTION



When connecting the bypass and load voltage from another model UPS to a Power Xpert 9395 UPS using the Eaton Fixed Master Sync Control accessory, use Phase A, Phase B, and Neutral connections from the other UPS. DO NOT connect the other model UPS Phase C bypass and load voltage to the Sync Control connection point when connecting to an Power Xpert 9395 UPS.

Table 3-8. Power Xpert 9395 UPS System Control Wiring Interconnections

From Non-Master UPS (9395)	To Sync Control	Function	Note
TB6-1	TB1-4	Bypass Voltage	14 AWG Twist Together
TB6-2	TB1-5		
TB6-3	TB1-6		
TB6-4	TB1-13	Load Voltage	14 AWG Twist Together
TB6-5	TB1-14		
TB6-6	TB1-15		
TB6-7	—	NOT USED	—
TB6-8	—	NOT USED	—
TB6-9	TB1-17	Bypass Voltage Phase B Return	14 AWG
TB6-10	—	NOT USED	—
TB-10 (AS400 Relay Card)	TB1-1	On Bypass Common	14 AWG Twist Together
TB-11 (AS400 Relay Card)	TB1-2	On Bypass NO	
TB3-1	TB1-22	Building Alarm 1 (Transfer to Bypass Disable)	14 AWG Twist Together
TB3-2	TB1-23	Building Alarm 1 Return	
TB3-3	TB1-26	Building Alarm 2 (Sync Control Trouble)	14 AWG Twist Together
TB3-4	TB1-27	Building Alarm 2 Return	
From Master UPS (9395)	To Sync Control	Function	Note
TB6-1	TB1-10	Bypass Voltage	14 AWG Twist Together
TB6-2	TB1-11		
TB6-3	TB1-12		
TB6-4	TB1-7	Load Voltage	14 AWG Twist Together
TB6-5	TB1-8		
TB6-6	TB1-9		

Table 3-9. Interconnections for Equipment Other Than Eaton Products (Refer to Vendor Installation Manual)

From Master Source	To Sync Control	Description	Note
Phase A	TB1-10	Bypass Reference Voltage (See Note)	Twist Together
Phase B	TB1-11		
Phase A	TB1-7	Sync Voltage	Twist Together
Phase B	TB1-8		
Phase C	TB1-9		

NOTE: If using the utility source as master or a source where bypass does not exist, add jumpers to the Fixed Master Sync Control as shown below:

FROM	TO
TB1-10	TB-7
TB1-11	TB1-8

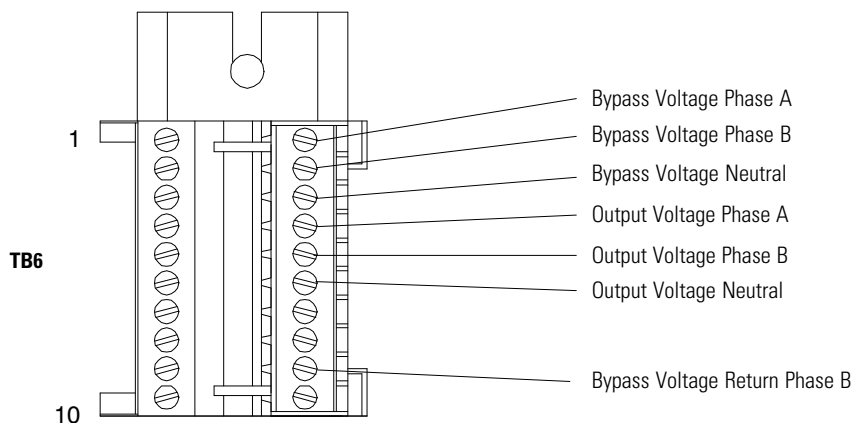
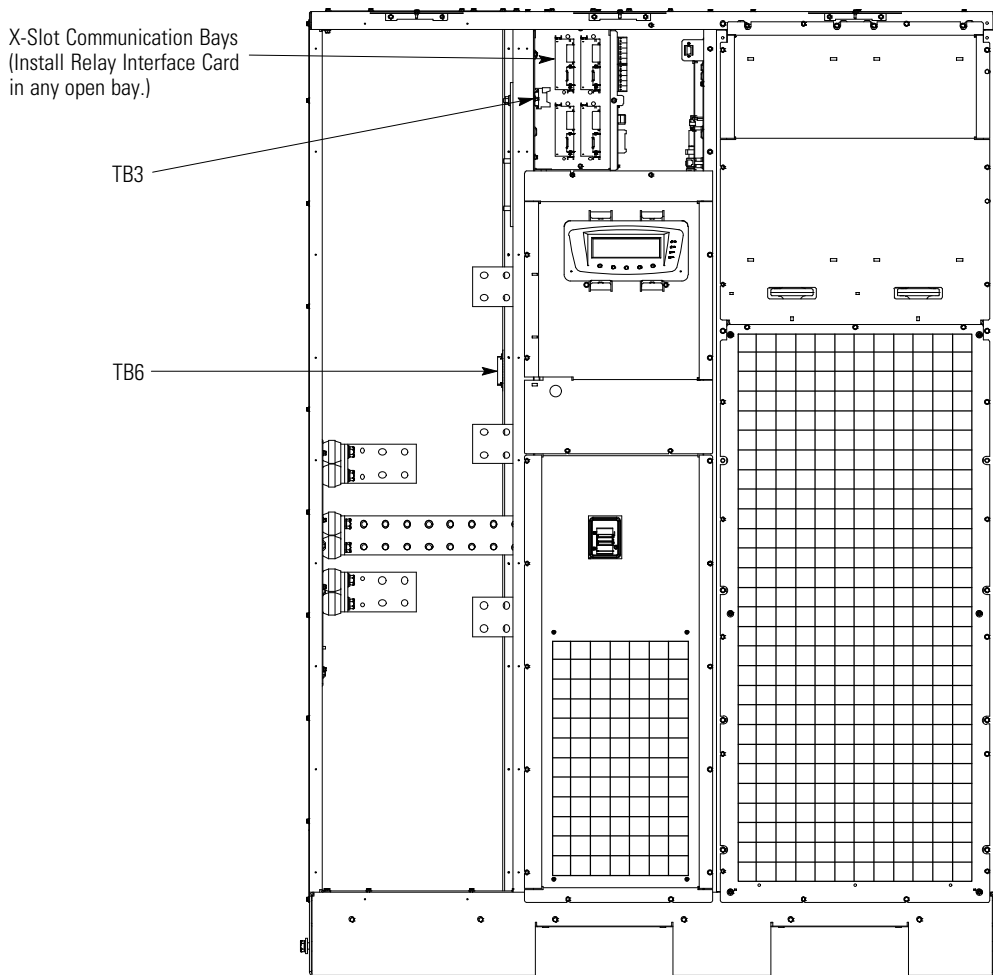
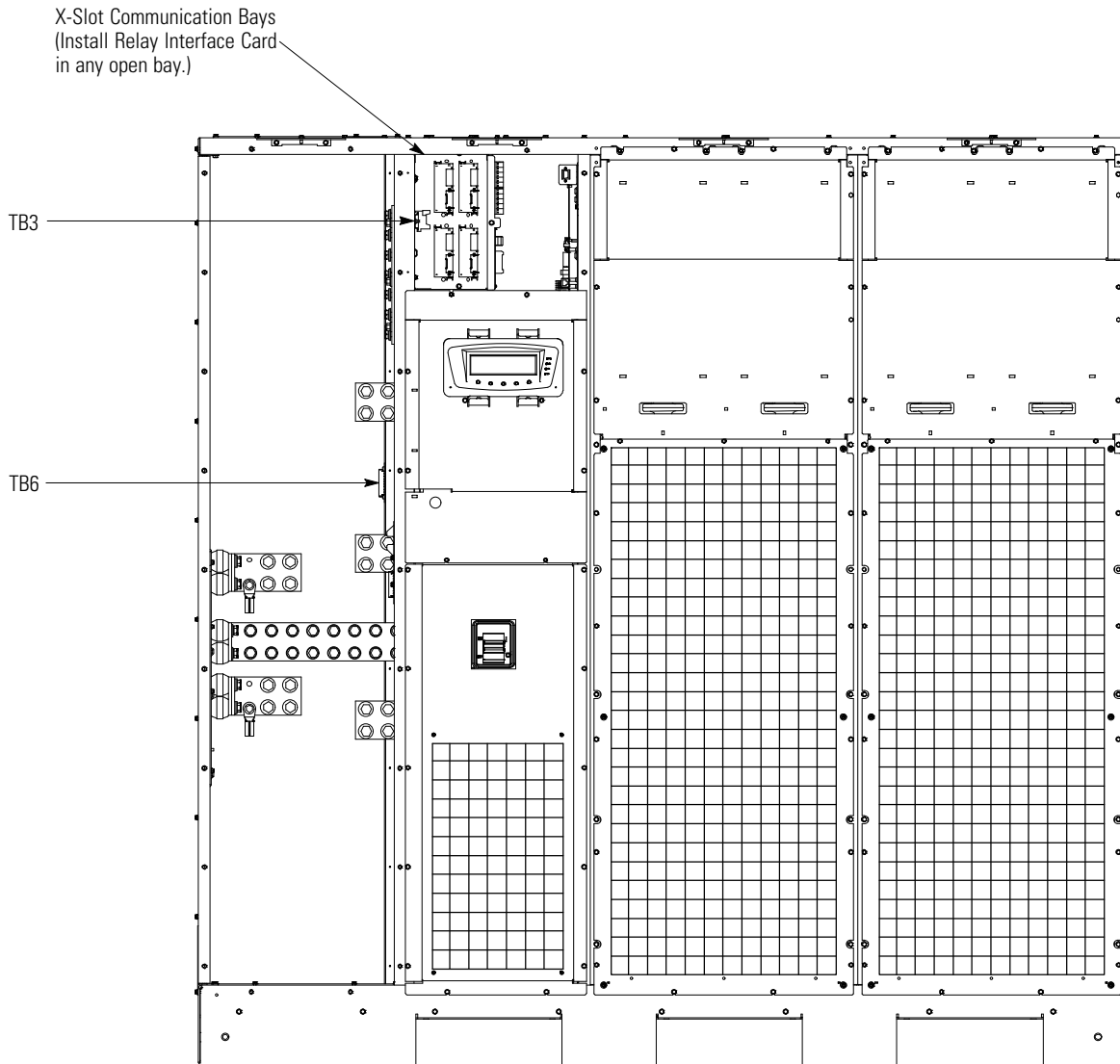

Figure 3-14. TB6 Terminal Block Detail (All Systems)



NOTE Interface connections are located in the same positions on the 9395 550/275 UPS (225-550 kVA) and the 9395 UPS (300 kVA).

Figure 3-15. Power Xpert 9395 UPS (225–275 kVA) Interface Locations for Eaton Fixed Master Sync Control



NOTE Interface connections are located in the same positions on the 9395 Plus 1 UPS (225-275 kVA).

Figure 3-16. Power Xpert 9395 UPS and Plus 1 UPS (450–550 kVA) Interface Locations for Eaton Fixed Master Sync Control

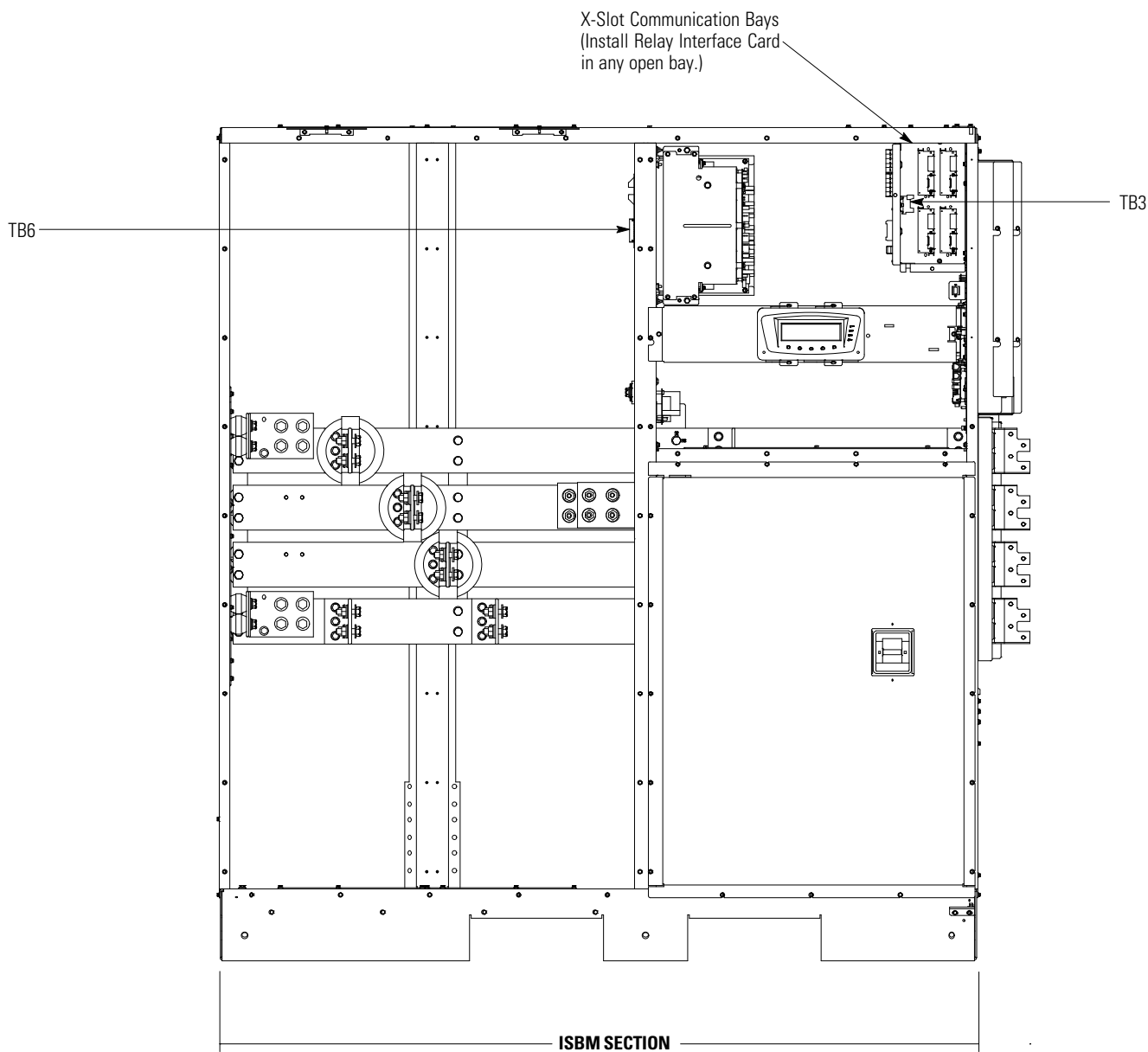

Figure 3-17. Power Xpert 9395 UPS and Plus 1 UPS (650–825 kVA) Interface Locations for Eaton Fixed Master Sync Control

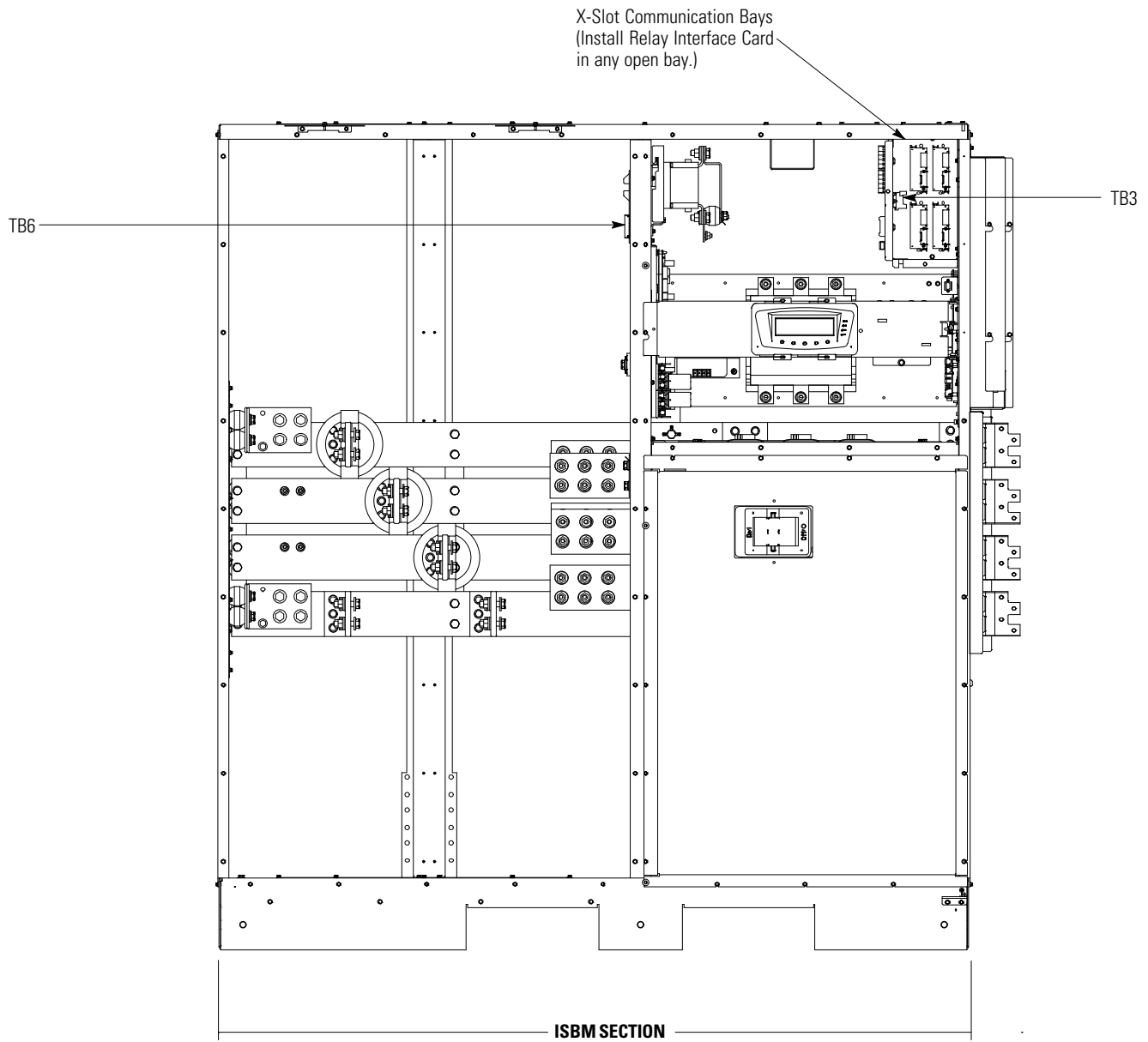

Figure 3-18. Power Xpert 9395 UPS (1000–1100 kVA) Interface Locations for Eaton Fixed Master Sync Control

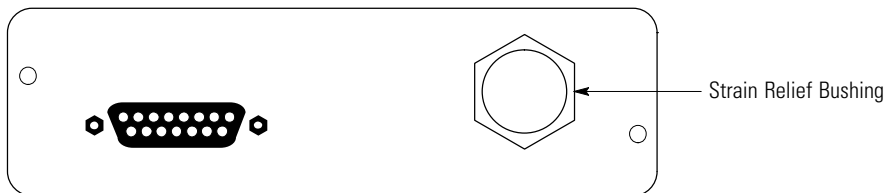

Figure 3-19. Relay Interface Card

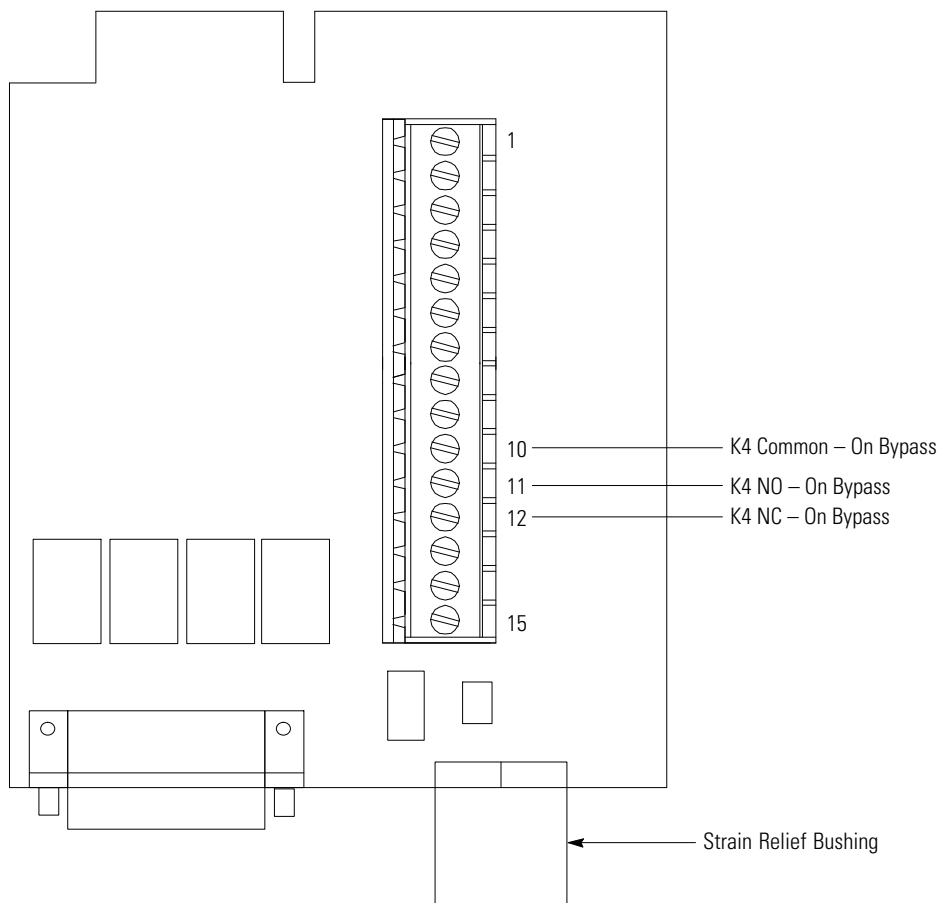

Figure 3-20. Relay Interface Card Terminals

This page intentionally left blank.

Chapter 4

Operation

This chapter describes the operation of the Eaton Fixed Master Sync Control with a UPS system.

4.1 Startup for UPS Systems Equipped with an Eaton Fixed Master Sync Control

Startup and operational checks must be performed by an authorized Eaton Customer Service Engineer, or the warranty terms as specified on page 5-1 become void. This service is offered as part of the sales contract for the UPS. Contact service in advance (usually a two-week notice is required) to reserve a preferred startup date.

4.2 Understanding Eaton Fixed Master Sync Control Operation



WARNING

Attempts to startup the SBM system yourself may damage equipment and/or your critical load. Such attempts may also invalidate your system warranty.



CAUTION

As shipped the Eaton Fixed Master Sync Control is configured for operation with a normally open contact for the "ON BYPASS" signal. The jumper across terminal points TB1-40 and TB1041 MUST be removed if a normally closed contact is used for the "ON BYPASS" signal. Removal of this jumper must be performed by an Eaton authorized service person. Removal or installation of this jumper by anyone other than an Eaton authorized service person may damage the equipment and/or the critical load and void the warranty.

The Eaton Fixed Master Sync Control maintains critical load synchronization of two separate single UPS systems or to an Eaton Hot Sync-Capacity System (non-master). See Figure 4-1 for a typical block diagram of the system. Synchronization of the UPS systems facilitates the uninterrupted transfer of customer loads from one load bus to another by means of downstream, dual-source, solid-state transfer switches. Enable the automatic synchronization action of the Eaton Fixed Master Sync Control by pressing the LOAD SYNC ENABLE pushbutton on the front of the panel. When enabled, the LOAD SYNC ENABLE pushbutton illuminates.

The Eaton Fixed Master Sync Control panel provides a three-phase synchronization reference to each system. Each system uses this reference to regulate the inverter phase relationship so that the two system outputs can maintain synchronization with each other. To establish the three-phase synchronization reference, each system provides bypass sensing voltage and output (critical load) bus voltage to the Eaton Fixed Master Sync Control.

Under normal operating conditions, bypass sensing voltage from the non-master system is provided back to its own inverter through the Sync Control. As long as the bypass sources feeding the non-master system and the master system are available and in-phase with each other and the master critical load is in phase with its own bypass, the non-master system remains synchronized with its own bypass source and the two systems remain synchronized with each other. If the non-master system's bypass becomes out of phase with the master system bypass (>0.1 Hz apart), the master critical load loses sync with its own bypass, or one or both sources become unavailable, the Sync Control provides a new synchronization reference to the slave system. The non-master system's new reference is provided by the Fixed Master Sync Control from the output (critical load) bus of the master system (See Figure 4-1).

When the two bypass sources regain availability and synchronization, the Eaton Fixed Master Sync Control provides the non-master system with its own bypass sensing voltage as a synchronization reference. Before resynchronization occurs, a 15-second preset time delay ensures the two bypass sources maintain acceptable synchronization.

To maintain a fault-tolerant arrangement, the Eaton Fixed Master Sync Control accounts for the following fault conditions or abnormal operating conditions:

- When the non-master system is synchronized to the master source, a transfer to bypass disable signal is sent to the non-master system. This inhibits any transfers to bypass on the non-master system
- If one UPS system loses its critical load bus voltage sensing, the non-master system synchronizes to its own bypass source.
- Dual redundant logic power supplies are incorporated within the Eaton Fixed Master Sync Control, ensuring both systems remain synchronized even during the loss of one of the logic power supplies. If one or both power supplies fail, an alarm is sent back to the slave system indicating a "SYNC CONTROL TROUBLE" alarm. These power supplies are powered from each system's critical load bus.
- With a complete loss of logic power to the Eaton Fixed Master Sync Control (due to component failure or power supply fault), the non-master system synchronizes to its own bypass source.

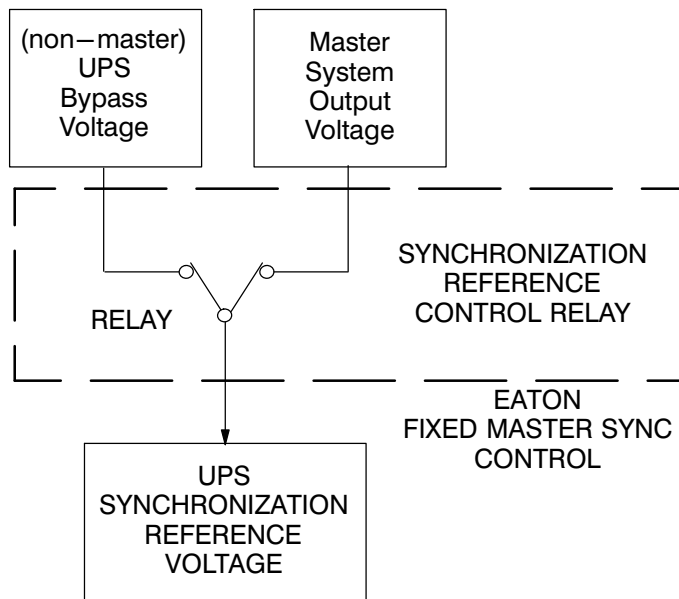

NOTE The Synchronization Reference Control relays are shown under normal conditions.

NOTE Dashed switch position of Synchronization Reference Control Relay 1 shows UPS in the non-master system mode.

Figure 4-1. Synchronization Reference Control

4.3 Operation

Perform the following procedure to set up the Eaton Fixed Master Sync Control for operation with your system. See Figure 4-2 and Table 4-1 for the location and explanation of the controls and indicators on the Eaton Fixed Master Sync Control.

1. Place the non-master system in normal operating mode. Refer to the applicable UPS installation and operation manual listed in paragraph 1.3 on page 1-4.
2. Press the LAMP TEST pushbutton to verify all indicators illuminate and are working correctly.
3. Depress the LOAD SYNC ENABLE pushbutton switch to enable the automatic synchronization control. The pushbutton illuminates when the synchronization control is activated.
4. To disable the automatic synchronization control, depress the LOAD SYNC ENABLE pushbutton and verify the LOAD SYNC ENABLE pushbutton is extinguished.

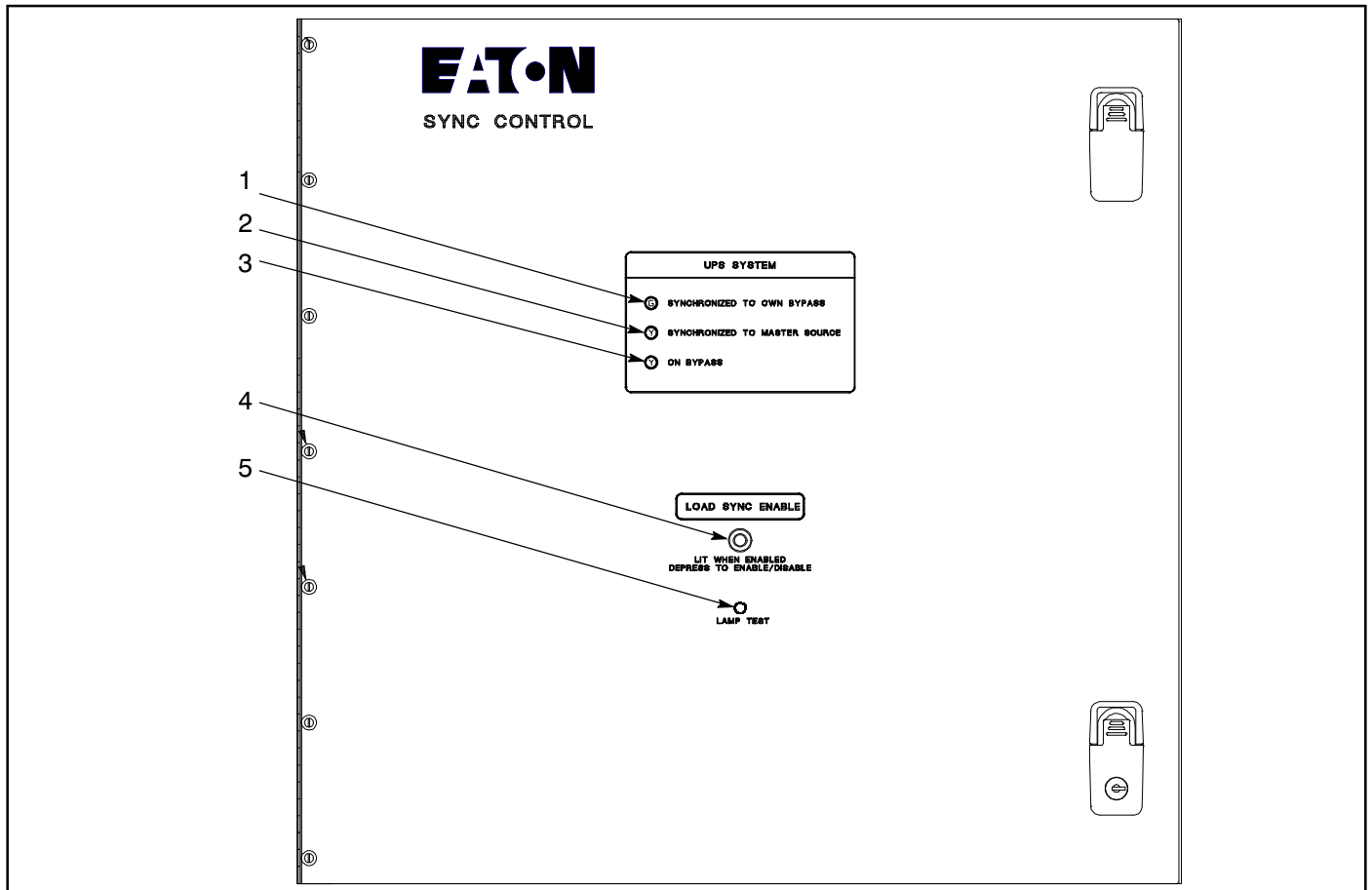

Figure 4-2. Eaton Fixed Master Sync Control Controls and Indicators

Table 4-1. Controls and Indicators

Item	Name	Function and Description
1	SYNCHRONIZED TO OWN BYPASS	When illuminated, indicates that the non-master system is synchronized to its own bypass.
2	SYNCHRONIZED TO MASTER SOURCE	When illuminated, indicates the non-master system is in the non-master system mode and is synchronized to the master load bus.
3	ON BYPASS	When illuminated, indicates the non-master system is on bypass. The SYNCHRONIZED TO OWN BYPASS light should also be illuminated.
4	LOAD SYNC ENABLE <i>LIT WHEN ENABLED DEPRESS TO ENABLE-DISABLE</i>	Enables or disables the automatic fixed master sync control unit. Switch is illuminated when load sync action is enabled.
5	LAMP TEST	Pressing the pushbutton illuminates all indicators on the Eaton Fixed Master Sync Control unit for visual testing.

4.4 Maintenance Operations

Maintenance should be scheduled on a periodic basis, recommended not to exceed one year. More frequent intervals are recommended if the equipment is subjected to highly repetitive operations.



DANGER

This UPS contains **LETHAL VOLTAGES**. All repairs and service should be performed by **AUTHORIZED SERVICE PERSONNEL ONLY**. There are **NO USER SERVICEABLE PARTS** inside the UPS.

Periodic inspections of the Eaton Fixed Master Sync Control should be made to determine if components, wiring, and connections exhibit evidence of overheating or damage.



CAUTION

Refer to the maintenance chapter in the applicable Eaton 9390 UPS or Power Xpert 9395 UPS Installation and Operation Manual listed in paragraph 1.3 on page 1-4 before beginning maintenance or repairs.

Chapter 5

Warranty

LIMITED FACTORY WARRANTY FOR EATON THREE-PHASE UPS PRODUCTS

WARRANTOR: The warrantor for the limited warranties set forth herein is Eaton, Inc., an Ohio Corporation (“Eaton”).

LIMITED WARRANTY: This limited warranty (this “Warranty”) applies only to the original end-user (the “End-User”) of the Eaton Three-Phase UPS Products (the “Product”) and cannot be transferred. This Warranty applies even in the event that the Product is initially sold by Eaton for resale to an End-User.

LIMITED WARRANTY PERIOD: The period covered by this Warranty for Product installed [and currently located] in the fifty (50) United States and the District of Columbia is twelve (12) months from the date of Product start-up or eighteen (18) months from the date of Product shipment, whichever occurs first, for parts coverage and 90 days from the date of Product start-up for labor coverage. The period covered by this Warranty for Product installed [and currently located] outside of the fifty (50) United States and the District of Columbia is twelve (12) months from the date of Product start-up or eighteen (18) months from the date of Product shipment, whichever occurs first, for parts coverage.

WHAT THIS LIMITED WARRANTY COVERS: The warrantor warrants that the Eaton three-phase UPS electronics, Eaton-built accessories, and Eaton-built battery cabinets (individually and collectively, the “Warranted Items”) are free from defects in material and workmanship. If, in the opinion of Eaton, a Warranted Item is defective and the defect is within the terms of this Warranty, Eaton’s sole obligation will be to repair or replace such defective item (including by providing service, parts, and labor, as applicable), at the option of Eaton. The Warranted Item will be repaired or replaced onsite at the End-User’s location or such other location as determined by Eaton. Any parts that are replaced may be new or reconditioned. All parts replaced by Eaton shall become the property of Eaton.

WHAT THIS LIMITED WARRANTY DOES NOT COVER: This Warranty does not cover any defects or damages caused by: (a) failure to properly store the Product before installation, including the “trickle charge” of batteries no later than the date indicated on the packaging; (b) shipping and delivery of the Product if shipping is FOB Factory; (c) neglect, accident, fire, flood, lightning, vandalism, acts of God, Customer’s neglect, abuse, misuse, misapplication, incorrect installation; (d) repair or alteration not authorized in writing by Eaton personnel or performed by an authorized Eaton Customer Service Engineer or Agent; or (e) improper testing, operation, maintenance, adjustment, or any modification of any kind not authorized in writing by Eaton personnel or performed by an authorized Eaton Customer Service Engineer or Agent.

This Warranty is not valid: (a) unless an authorized Eaton Customer Service Engineer (in the USA) or Agent (outside of the USA) performs startup and commissioning of the Product; (b) if the Product is moved to a new location by someone other than an authorized Eaton Customer Service Engineer (in the USA) or Agent (outside of the USA); or (c) if the Product’s serial numbers have been removed or are illegible. Any Warranted Items repaired or replaced pursuant to this Warranty will be warranted for the remaining portion of the original Warranty subject to all the terms thereof. Labor warranty is not provided for Product located outside of the fifty (50) United States or the District of Columbia. Any equipment, parts, or materials included in the Product and not manufactured by Eaton are warranted solely by the manufacturer of such equipment, parts, or materials and are not included as part of this Warranty. Batteries are not warranted by Eaton.

THIS WARRANTY IS THE END-USER’S SOLE REMEDY AND IS EXPRESSLY IN LIEU OF, AND THERE ARE NO OTHER EXPRESSED OR IMPLIED GUARANTEES OR WARRANTIES (INCLUDING ANY IMPLIED WARRANTY OF MERCHANTABILITY OR FITNESS FOR ANY PURPOSE, WHICH ARE EXPRESSLY DISCLAIMED).

LIMITATION OF LIABILITY: In no event shall Eaton be liable for any indirect, incidental, special, or consequential damages of any kind or type whatsoever, or based on any claim or cause of action, however denominated. Eaton shall not be responsible for failure to provide service or parts due to causes beyond Eaton’s reasonable control. In no case will Eaton’s liability under this Warranty exceed the replacement value of the Warranted Items.

END-USER’S OBLIGATIONS: In order to receive the benefits of this Warranty, the End-User must use the Product in a normal way, follow the Product’s installation, operation and maintenance manual, and protect against further damage to the Product if there is a covered defect.

OTHER LIMITATIONS: Eaton’s obligations under this Warranty are expressly conditioned upon receipt by Eaton of all payments due to it (including interest charges, if any). During such time as Eaton has not received payment of any amount due to it for the Product, in accordance with the contract terms under which the Product is sold, Eaton shall have no obligation under this Warranty. Also during such time, the period of this Warranty shall continue to run and the expiration of this Warranty shall not be extended upon payment of any overdue or unpaid amounts.

COSTS NOT RELATED TO WARRANTY: The End-User shall be invoiced for, and shall pay for, all services not expressly provided for by the terms of this Warranty, including without limitation site calls involving an inspection that determines no corrective maintenance is required. Any costs for replacement equipment, installation, materials, freight charges, travel expenses, or labor of Eaton representatives outside the terms of this Warranty will be borne by the End-User.

OBTAINING WARRANTY SERVICE: In the USA, call the Eaton Customer Reliability Center 7x24 at 800-843-9433. Outside of the USA, call your local Eaton sales or service representative, or call the Eaton Customer Reliability Center in the USA at 919-870-3028. For comments or questions about this Limited Factory Warranty, write to the Customer Quality Representative, 3301 Spring Forest Road, Raleigh, North Carolina 27616 USA.

This page intentionally left blank.



P-16400023 1